

VALVES - SOLENOID LOW PRESSURE

MODEL: 1251 - SVL

Revision: 0

BULLETIN
1251

DESCRIPTION

The SVL magnetic gas valves are primarily designed for use on pilot gas lines as a shut-off valve and as a main line valve. These normally closed, direct acting, 2-way, electrically actuated valves will handle all gases, including natural, LPG, sour gas and scrubbed coke gas. Operating pressures of 1/2 psig or higher, depending upon size. Soft seat, diaphragm guided design ensures tight shut-off.

SPECIFICATIONS

Service Natural, manufactured, mixed, and LP gases.

Body Material Aluminum

Seat Type Buna - N (2SVL)
Nitrile (3SVL to 12SVL)

Electrical voltage 120v - 60 Hz or 110v - 50 Hz. Class "F" coil (2SVL)
110-120v, 50-60 Hz. Class "F" coil (3SVL to 12SVL)

Electrical wiring 2 - wire control circuit. Replaceable coil.
Solenoid jacket rotates 360°. 18" wire leads.



FEATURES

- Closes on current failure.
- Soft seat - tight shutoff.
- Removable solenoid -- facilitates field change.
- UL Listed. AGA, CGA, and CSA Certified.
- 1/4" - 3/4" FM Approved.

CAUTION: Operation of combustion equipment can be hazardous resulting in bodily injury or equipment damage. Each burner should be supervised by a combustion safeguard and only qualified personnel should install, make system adjustments and perform any required service.



ORDAN THERMAL PRODUCTS LTD
Combustion Equipment & Controls for Industry
21 Amber St # 9, Markham Ontario Canada L3R 4Z3
Tel: (905) 475-9292 Fax: (905) 475-3286
www.ordanthermal.com

NOTICE: PYRONICS practices a policy of continuous improvement in the design of its products. It reserves the right to change the specifications at any time without prior notice.

VALVES - SOLENOID LOW PRESSURE

BULLETIN 1251
PAGE NO. 2

DIMENSIONS

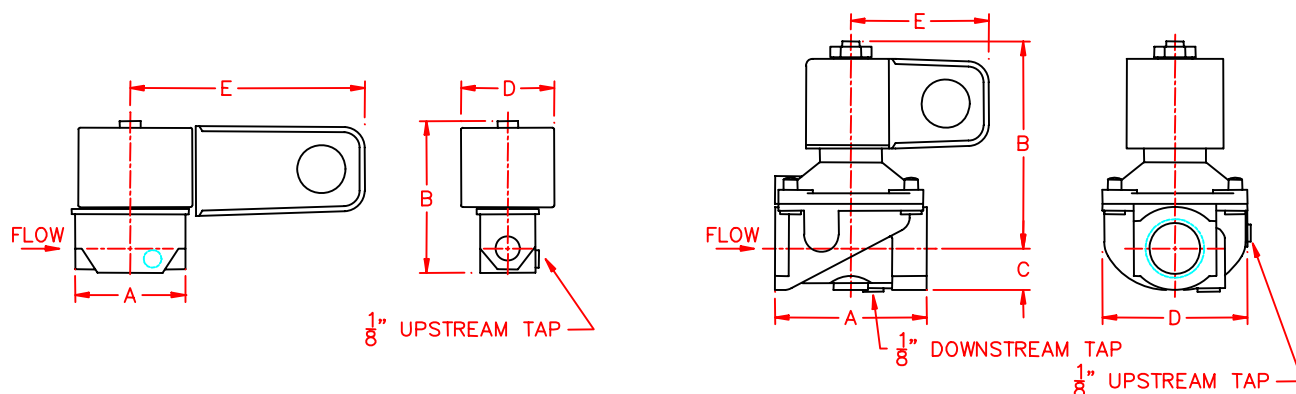

2SVL

3SVL TO 12SVL

Model Number	Pipe Size NPT	# Pipe Plugs	A	B	C	D	E	Weight	
								Lbs.	Kgs.
2SVL	1/4	1	2.00	2.75	----	1.69	4.19	1.0	0.45
3SVL	3/8	2	2.75	3.64	0.56	2.63	2.42	1.2	0.54
4SVL	1/2	2	2.75	3.64	0.56	2.63	2.42	1.2	0.54
6SVL	3/4	2	2.75	3.77	0.75	2.63	2.42	1.3	0.59
8SVL	1	2	3.50	3.84	0.88	3.25	2.42	1.6	0.73
10SVL	1-1/4	2	5.25	6.83	1.25	3.87	2.85	4.0	1.81
12SVL	1-1/2	2	5.25	6.83	1.25	3.87	2.85	4.0	1.81

NOTE: All dimensions are in inches.

SPECIFICATIONS

Model Number	Pipe Size NPT (inches)	Orifice Size (inches)	Cv Factor	Gas Capacity * (Btu/Hr.)	Maximum Operating Diff. Press. (psi)	Fluid & Ambient Temperature (°F)		Ambient Temperature (°F)		Media Temp. Nominal (°F)	Watt Rating/ Class of Coil Insulation	Power Consumption		UL	FM	CSA
						Min.	Max.	Min.	Max.			VA Holding	VA Inrush			
2SVL	1/4	0.313	1.1	59,000	15.0	- 40	125	----	----	----	6.1/F **	16	40	X	X	X
3SVL	3/8	0.456	4.0	215,000	0.5	----	----	32	104	77	10.0/F	18	77	X	X	X
4SVL	1/2	0.687	6.0	350,000	0.5	----	----	32	104	77	10.0/F	18	77	X	X	X
6SVL	3/4	0.812	9.0	520,000	0.5	----	----	32	104	77	10.0/F	18	77	X	X	X
8SVL	1	1.000	14.0	755,000	0.5	----	----	32	104	77	10.0/F	18	77	X		X
10SVL	1-1/4	1.250	18.0	1,028,000	1.5	----	----	32	104	77	17.5/F	30	168	X		X
12SVL	1-1/2	1.250	24.0	1,372,000	1.5	----	----	32	104	77	17.5/F	30	168	X		X

* 1" W.C. Drop @ 2" W.C. Inlet Pressure, 1,000 Btu/Cu. Ft. or more, 0.64 Specific Gravity Gas.

** 8.1 watts on 50 Hz service.

ORDERING INFORMATION

1. Specify Model Number and Quantity
2. Shipping Instructions