



# LEVER ACTING DESIGN GAS APPLIANCE PRESSURE REGULATOR



**CSA 6.3 and ANSI Z21.18**  
**Design Certified - 325-3, 325-5A**

### Maximum Inlet Pressure:

ANSI Z21.18 Certified - 325-3, 325-5A .....2 psi (140 mbar), 5 psi (345 mbar)

Maxitrol-tested: all models.....10 psi (690 mbar)

*With 12A09 or 12A39:*

Max. inlet pressure (LP).....2 psi (140 mbar)  
Max. inlet pressure (natural).....5 psi (345 mbar)

### Emergency Exposure Limits

All models (inlet side only).....65 psi (4.5 bar)

### Maximum Individual Load

Largest single appliance served by the regulator

325-3.....100,000 Btu/hr  
325-5A.....250,000 Btu/hr  
325-7.....900,000 Btu/hr

### Capacity:

Total load of all appliances combined

325-3 (3/8", 1/2").....150,000 Btu/hr  
325-5A (1/2", 3/4", 1").....300,000 Btu/hr  
325-7 (1-1/4", 1-1/2").....1,000,000 Btu/hr

### Ambient Temperature Limits

All models.....-40° to 205°F (-40° to 96°C)  
DVGW.....32° to 140°F (0° to 60°C)  
EN.....5° to 176°F (-15° to 80°C)

### Vent Pipe Connection Size:

325-3 .....1/8" NPT  
325-5A.....3/8" NPT  
325-7.....1/2" NPT

**Gases:** Suitable for use with natural, manufactured, mixed, LP gases and LP gas air mixtures.

**Note:** All Maxitrol gas appliance regulators must be installed and operated in accordance with Maxitrol's 'Safety Warning' bulletin.

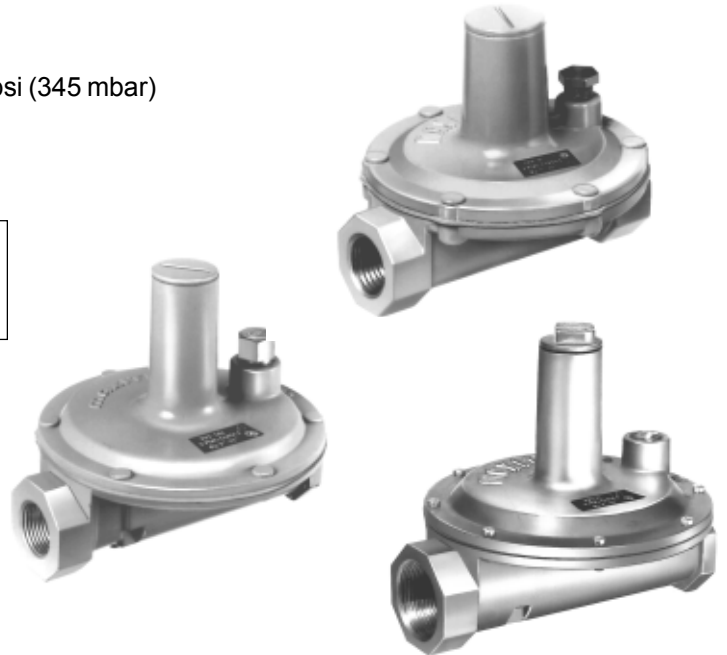

**325-3\*, 325-5A\*, 325-7**  
**Pipe sizes from 3/8" to 1-1/2"**

\* Design Certified - 325-3, 325-5A

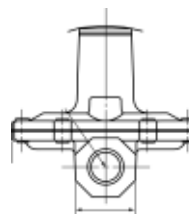

*Upright*

When vented to the outdoors the 325 Series is suitable for multi-poise mounting. When using the **vent limiting device**, the regulator (325-3, 325-5A) must be mounted in a horizontal upright position. Install the regulator properly with gas flowing as indicated by the arrow on the casting (also see the Safety Warning Instructions bulletin).



## Lever Acting Design

### 325 series

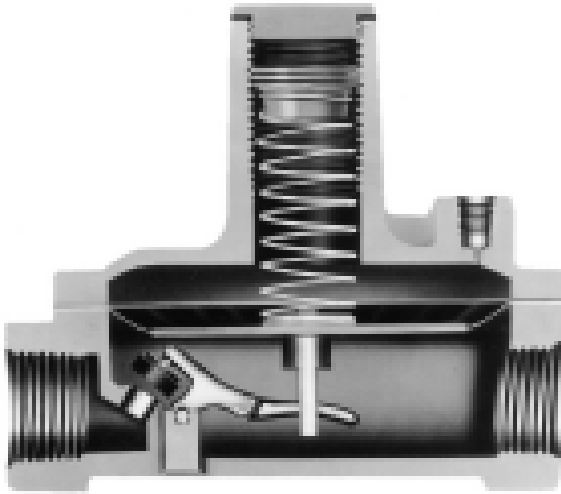

#### 325-3\*, 325-5A\* & 325-7

##### FEATURES:

- Designed for multi-poise mounting...
- Self-aligning valve with lever action for dead end lockup...
- Durable, corrosion-resistant construction...
- High performance type for pounds to inches reduction...
- Available in six pipe sizes from 3/8" to 1-1/2"...

##### BENEFITS:

- Ease of installation...
- Longer life, less maintenance...
- May be used for both 2 psi and 5 psi corrugated stainless steel tubing (CSST) systems.
- Precise regulation from pilot flows to full regulator capacity...
- Meets many utility specifications.

The 325 Series is a pounds to inches regulator, meeting utility specifications. The 325 Series regulator is for use on residential, commercial, and industrial applications where adequate inlet pressures are available.

They are a high performance type regulator and can be used as a single stage regulator - reducing pounds pressure to normal burner pressure. They can also be used as a line regulator on equipment already fitted with an appliance regulator.

The 325-3 and 325-5A models are CSA certified and widely accepted with 2 psig and 5 psig house piping systems. In fact, the entire concept (using semi-rigid copper or flexible stainless steel tubing) would not have been possible without the development of the compact 325 series regulators.

The 325-7, designed especially for the growing segment of electronic ignition equipment, permits the utilization of greater capacities without sacrificing performance. All 325 Series models are also certified through DVGW to European EN 88.

To deliver positive dead-end lock up, the 325 Series feature a high leverage valve linkage assembly. Lockup pressure can vary with the speed of the solenoid valve and its location. The regulators are capable of precise regulating control from full flow down to pilot flows.

As an optional accessory, the 325-3 and 325-5A offer automatic vent limiting devices. The 12A09 and 12A39 vent limiters eliminate the need to run vent piping to a safe area - in the event of a diaphragm rupture, gas

escapement is limited to within the ANSI/CSA standards level.

The 325 Series regulators are Maxitrol-tested for inlet pressures up to 10 psi (CSA certified for 2 psi and 5 psi), and withstand emergency exposure inlet pressure up to 65 psi. With the 12A09 or 12A39 installed, maximum inlet pressure is 2 psi (LP) and 5 psi (natural). Inlet pressures exceeding 2 psi (LP), or 5 psi (natural) require a vent line.

The self-aligning valve is made of nitrile rubber. Housings are durable aluminum die castings and all internal parts are carefully selected and corrosion resistant. The diaphragms are of high quality supported synthetic rubber compounds.

The 325 Series regulators are suitable for multi-poise mounting. **But when using the vent limiting device, the regulator (325-3, 325-5A) must be mounted in a horizontal upright position.** Install the regulator properly with gas flowing as indicated by the arrow on the casting.

These regulators provide no downstream over-pressure protection in the event of failure. At supply pressures in excess of 2 psi they should not be used unless downstream appliance controls are rated for supply pressure or protected by some other means. Consult Maxitrol Company for additional assistance.

**\* CSA design certified**

# Capacities and Pressure Drop

CAPACITIES - based on 1" w.c. pressure drop, from set point\*. 0.64 sp gr gas expressed in CFH (m<sup>3</sup>/h).

Model Number	Outlet Pressure Set Point	CSA Max. CFH	Operating Inlet Pressure					
			1/2 psi (34 mbar)	3/4 psi (52 mbar)	1 psi (69 mbar)	2 psi (138 mbar)	5 psi (345 mbar)	10 psi (690 mbar)
325-3*	4.0" w.c.	150	160 (4.5)	190 (5.4)	220 (6.2)	220 (6.2)	300 (8.5)	320 (9.1)
	7.0" w.c.	150	120 (3.4)	150 (4.2)	180 (5.1)	220 (6.2)	290 (8.2)	320 (9.1)
	10.0" w.c.	150	100 (2.8)	120 (3.4)	150 (4.2)	220 (6.2)	280 (7.9)	320 (9.1)
325-5A*	4.0" w.c.	300	300 (8.5)	340 (9.6)	416 (11.8)	500 (14.2)	600 (17.0)	680 (19.3)
	7.0" w.c.	300	245 (6.9)	315 (8.9)	340 (9.6)	480 (13.6)	600 (17.0)	680 (19.3)
	10.0" w.c.	300	225 (6.4)	270 (7.6)	312 (8.8)	430 (12.2)	560 (15.9)	680 (19.3)
325-7	4.0" w.c.	-	670 (19.0)	900 (25.5)	1050 (29.7)	1450 (41.1)	1750 (49.6)	2000 (56.6)
	7.0" w.c.	-	590 (16.7)	760 (21.5)	900 (25.5)	1250 (35.4)	1750 (49.6)	2000 (56.6)
	10.0" w.c.	-	470 (13.3)	650 (18.4)	800 (22.7)	1250 (35.4)	1750 (49.6)	2000 (56.6)

\*NOTE: Maximum Individual Load: 325-3 is 100 CFH (2.8 m<sup>3</sup>/h), 325-5A is 250 CFH (7.0 m<sup>3</sup>/h), 325-7 is 900 CFH (25.5 m<sup>3</sup>/h)  
Approval based on use as an appliance regulator.

PRESSURE DROP - 0.64 sp gr gas expressed in CFH (m<sup>3</sup>/h) (for system pressure drop calculations)

Model Number	7.0" w.c. (17 mbar)	1/2 psi (34 mbar)	3/4 psi (52 mbar)	1 psi (69 mbar)	2 psi (138 mbar)
325-3	145 (4.0)	204 (5.8)	250 (7.0)	289 (8.2)	-
325-5A	338 (9.6)	476 (13.5)	583 (16.5)	673 (19.1)	-
325-7	690 (19.5)	972 (27.6)	1191 (33.8)	1375 (39.0)	1975 (55.9)

## Sizing Instructions

When 325 Series regulators are used on 2 psig piping systems - oftentimes the 2 psig residential systems are sized with a 1-1/2 psi pressure drop through the copper or stainless steel tubing. This means there will be 2 psi at the inlet of the regulator under no flow conditions, and 1/2 psi at the regulator inlet under maximum flow conditions.

To select a 325 series appliance regulator of ample flow - one must know:

1. Available inlet pressure (maximum static/minimum operating)
2. Desired outlet pressure.
3. Required maximum flow rate.
4. Pipe size.

Example: To select a 325 series regulator of ample capacity to handle flow. . .

### KNOWN:

Desired flow rate 145 CFH; pipe size 1/2"; operating inlet pressure 2 psi; outlet pressure 7" w.c.; lockup required.

### SOLUTION:

Check pressure drop chart above - the 325-3's pressure drop at a flow rate of 145 CFH is 7" w.c. - well below the available differential of 1.75 psi. The 325-3 (1/2") used with a 4" to 12" spring, set at 7", is the correct regulator to use for this application.

## Pressure Drop Chart

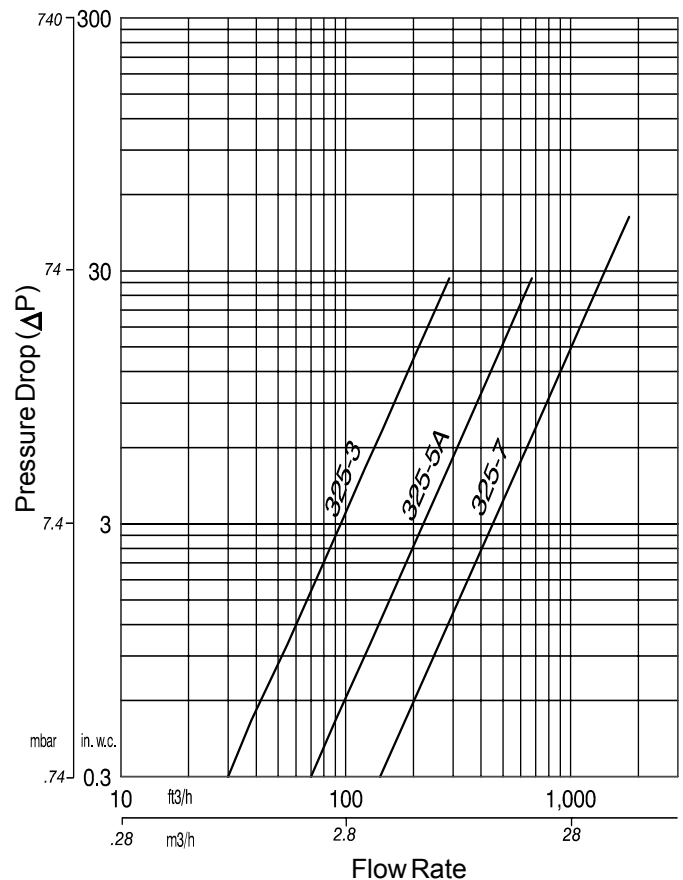

# Dimensions and Spring Ranges

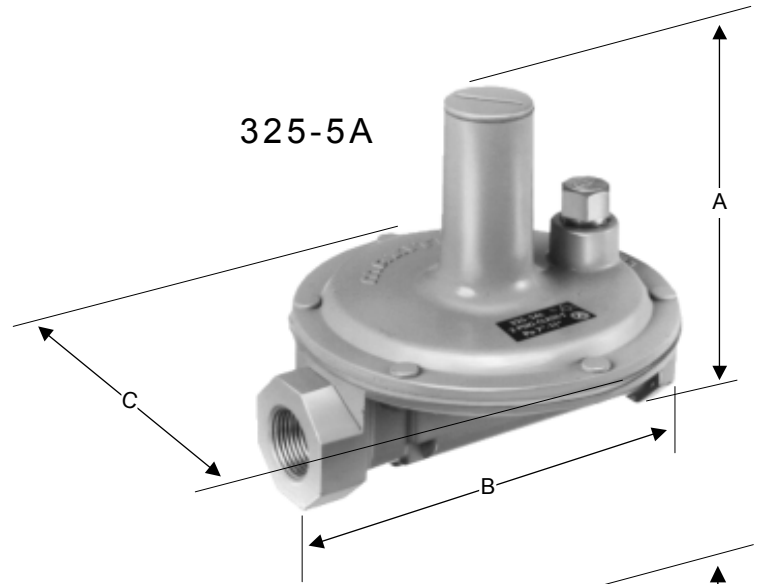
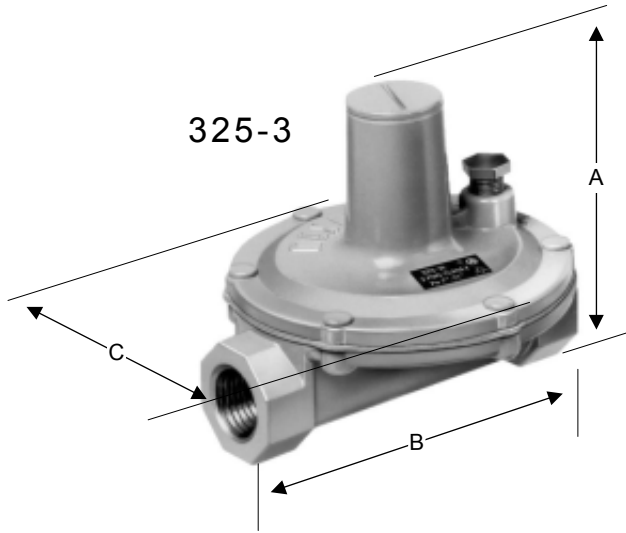

## DIMENSIONS - inches (millimeters)

Model Number	Pipe Size*	Swing Radius	Call-Outs		
			A	B	C
325-3	3/8 x 3/8 1/2 x 1/2	3 (76)	3-1/2 (89)	4-1/4 (108)	3-7/8 (98)
325-5A	1/2 x 1/2 3/4 x 3/4 1 x 1	4-7/8 (124)	5-1/4 (133)	5-7/8 (149)	5-7/16 (138)
325-7	1-1/4 x 1-1/4 1-1/2 x 1-1/2	6-1/8 (156)	7-1/4 (184)	8 (203)	7 (178)

\* standard models NPT, 'M' models available with BSP threads

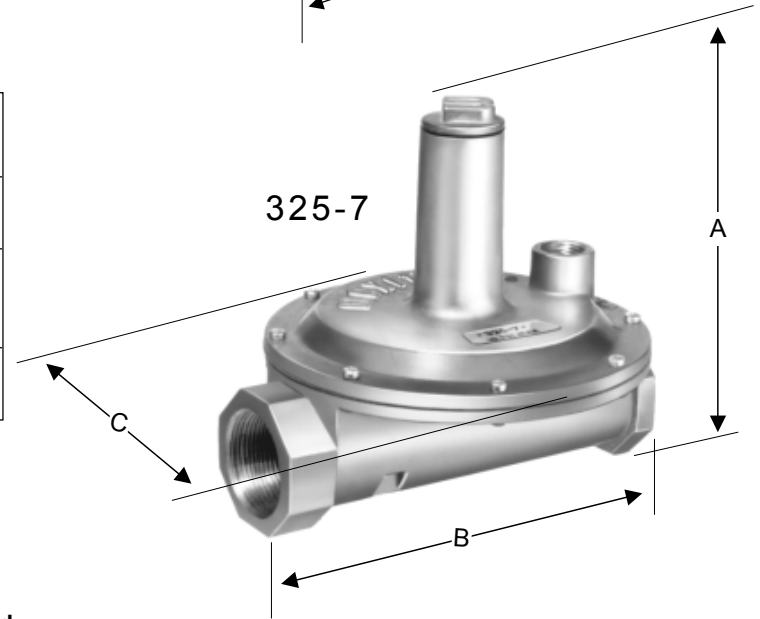

## SPRING SELECTION CHART - inches w.c. (mbar) unless noted

Model Number	CSA Certified				Standard Spring	Other Springs Available			
	2 psi (138 mbar)		5 psi (345 mbar)						
325-3	5 - 9 (12.5 - 22.5)	7 - 11 (17 - 27)	6 - 10 (15 - 25)	7 - 11 (17 - 27)	4 to 12 (10 to 30)	2 - 6 (5 - 15)	10 - 22 (25 - 55)	15 - 30 (37 - 75)	1 - 2 psi (69 - 139)
325-5A	5 - 9 (12.5 - 22.5)	7 - 11 (17 - 27)	6 - 10 (15 - 25)	7 - 11 (17 - 27)	4 to 12 (10 to 30)	2 - 6 (5 - 15)	10 - 22 (25 - 55)	15 - 30 (37 - 75)	1 - 2 psi (69 - 139)
325-7	-	-	-	-	4 to 12 (10 to 30)	2 - 5 (5 - 12)	10 - 22 (25 - 55)	15 - 30 (37 - 75)	20 - 42 (50 - 104)

A copyrighted publication of

**MAXITROL**®  company

