

FLOW RATE AND PRESSURE TRANSMITTER ESA PT-II SERIES

FEATURES

GENERAL

- Supply voltage: 115 or 230 Vac $\pm 10\%$
- Frequency: 50/60 Hz
- Absorption: 7 VA
- Working temperature: 0 \div 60 $^{\circ}$ C
- Storage temperature: -20 \div 80 $^{\circ}$ C
- Panel sealing: IP 54
- Mounting position: vertical (via M4 threaded holes)
- Atmospheres: not suitable for explosive and corrosive environment
- Dimensions: 180X150X80 mm
- Weight: 1300 g
- Serial communication interface: RS-485 2 wires (max 32 units)
can be expanded up to 254 units
- Serial communication protocol: Modbus-RTU
- Flow rate temperature compensation: available
- Flow rate pressure compensation: available

INPUTS

- Differential pressure sensors: 0 \div 100 mbar, 0 \div 300 mbar
-10 \div 10 mmH₂O, -50 \div 50 mmH₂O, -100 \div 100 mmH₂O
0 \div 10 mmH₂O, 0 \div 50 mmH₂O, 0 \div 100 mmH₂O
- Maximum relative pressure: 300 or 500 mbar
depending on model (see sensor)
- Pressure input connection: copper pipe union \varnothing 6X4
- Temperature sensor: J 0 \div 800 $^{\circ}$ C (\pm 4 $^{\circ}$ C)
K 0 \div 1250 $^{\circ}$ C (\pm 6.5 $^{\circ}$ C)
- "Cold" junction compensation: 0 \div 60 $^{\circ}$ C
- Optional analogue input signal (*): 0 \div 20 mA or 4 \div 20 mA
(RL 150 Ω)

* Not available if there is no EXPC expansion card

OUTPUTS

- Analogue output signal: 0 \div 20 mA or 4 \div 20 mA (RL max 250 Ω);
centre scale (12mA) available with null input signal
- Optional digital output signal (*): relay (NO) with maximum load
3A @230Vcos ϕ =0.5

(*) Not available if there is no EXPC expansion card.



F721001

Patent nr. I 1268539

DISPLAY

- Upper display: 8 digit alphanumeric. Height 0.2" Colour: red
- Lower display: 4 digit x 7 segment LED. Height 0.5" Colour: red
- Luminosity: adjustable from 13% to 100%

APPLICATIONS

- Air/gas differential pressure indicator.
- Temperature indicator ($^{\circ}$ C or $^{\circ}$ F) differential pressure (either mbar, mmH₂O, Pa or incWC), flow (either Nm³/h or cfm), and transmitted signal (mA).
- Current signal transmitter (0 \div 20 mA, 4 \div 20 mA), proportional to pressure or flow rate.
- Flow meter with temperature and pressure compensation.
- Resettable totalizer.

CAUTION: Operation of combustion equipment can be hazardous resulting in bodily injury or equipment damage. Each burner should be supervised by a combustion safeguard and only qualified personnel should install, make system adjustments and perform any required service.



ORDAN THERMAL PRODUCTS LTD
Combustion Equipment & Controls for Industry
21 Amber St # 9, Markham Ontario Canada L3R 4Z3
Tel: (905) 475-9292 Fax: (905) 475-3286
www.ordanthermal.com

NOTICE: PYRONICS practices a policy of continuous improvement in the design of its products. It reserves the right to change the specifications at any time without prior notice.

DESCRIPTION

ESA PT-II is a displaying, transmitting and field-totalizing instrument, a microprocessor-operated transducer-receiver of positive or negative differential pressures as well as a transmitter of current signals which can be sent through a double-wire connection to other remote devices such as electronic pressure or flow rate regulators, electronic pressure switches, pressure or flow rate indicators, flow rate totalizers, recorders, and so on. ESA PT-II can be driven from any measuring devices (calibrated flange, annubar, relative pressure intake) producing a differential pressure ranging between lower and upper threshold. The differential pressure sensor is the main input to measure flow rate; the temperature probe allows flow rate to be automatically compensated at the working temperature of the fluid. Furthermore, the instrument, via the optional EXP-C card may receive the fluid pressure value from another transmitter and automatically compensate the flow rate. Temperature and pressure compensation values may also be sent by the supervisor by means of the serial line. Moreover it is possible to transmit the results of all measuring to a remote unit either via a current signal or RS-485 serial line.

Moreover the device, if there is the optional EXPC expansion card, allows for a digital output which is enabled when the totalized flow reaches a set value.

In the steady state mode, the upper (8 digit alphanumeric) display shows the name of the physical quantity which is being examined whereas the lower (4 digit numeric) display shows the value of the quantity under examination. The following quantities may be displayed:

- Differential or relative pressure (mbar or mmH₂O, or Pa, or incWC)
- Instant flow rate (Nm³/h or cfm)
- Total flow rate (Nm³/h or cfm)
- Fluid temperature (°C or °F)
- Optional input current (mA)
- Fluid pressure (mbar or mmH₂O)
- Transmitted equivalent current (mA)

ESA PT-II may be configured to the preferences of any user. When programming it, it is possible to directly set the parameters which are user configurable. For instance it is possible:

- To set the values concerning the measuring of the instant flow rate and to either enable or disable temperature and pressure compensations;
- To select the quantity (differential pressure or instant flow rate) associated with the current signal or specific signal;
- To set pressure and instant flow rate values associated with the maximum (20 mA) and minimum (4 or 0 mA) value of the transmitted current signal;
- To select parameters for serial communication.
- Select the unity of measure of the quantities.

The instrument can operate in two different modes:

- Automatic mode (Automode): that is in steady state mode.
- Programming mode (Program.): that is parameter setting mode.

SENSOR FEATURES

Five different versions of ESA PT-II are available, according to the pressure range required. The main features of the different versions are listed below:

ESA PT-II 0÷100 mbar (type A) :

Nominal span	0 ÷ 100 mbar
Minimum span	0 ÷ 5 mbar
Input maximum relative pressure	500 mbar
Maximum differential pressure between the two inputs	500 mbar
Accuracy of reading: range 0 ÷ 10 mbar range 10 ÷ 25 mbar range 25 ÷ 100 mbar	<1% F.S. ± 0.1 mbar ± 1 digit ± 0.25 mbar ± 1 digit ± 1 mbar ± 1 digit

CAUTION: Operation of combustion equipment can be hazardous resulting in bodily injury or equipment damage. Each burner should be supervised by a combustion safeguard and only qualified personnel should install, make system adjustments and perform any required service.



ORDAN THERMAL PRODUCTS LTD
Combustion Equipment & Controls for Industry
21 Amber St # 9, Markham Ontario Canada L3R 4Z3
Tel: (905) 475-9292 Fax: (905) 475-3286
www.ordanthermal.com

NOTICE: PYRONICS practices a policy of continuous improvement in the design of its products. It reserves the right to change the specifications at any time without prior notice.

ESA PT-II 0÷300 mbar (type B):

Nominal span	0 ÷ 300 mbar
Minimum span	0 ÷ 20 mbar
Input maximum relative pressure	500 mbar
Maximum differential pressure between the two inputs	500 mbar
Accuracy of reading: range 0 ÷ 20 mbar range 20 ÷ 50 mbar range 50 ÷ 300 mbar	<1% F.S. ± 0.75 mbar ± 1 digit ± 1.5 mbar ± 1 digit ± 3 mbar ± 1 digit

ESA PT-II -10÷10mmH2O (type C):

Nominal span	-10 ÷ 10 mmH2O / 0 ÷ 10 mmH2O
Minimum span	-5 ÷ 5 mmH2O
Input maximum relative pressure	3000 mmH2O
Maximum differential pressure between the two inputs	3000 mmH2O
Accuracy of reading: range 0 ÷ 2.5 mmH2O and 0 ÷ -2.5 mmH2O range 2.5 ÷ 5 mmH2O and -2.5 ÷ -5 mmH2O range 5 ÷ 10 mmH2O and -5 ÷ -10 mmH2O	<4% F.S. ± 0.2 mmH2O ± 1 digit ± 0.2 mmH2O ± 1 digit ± 0.4 mmH2O ± 1 digit

ESA PT-II -50÷50mmH2O (type D):

Nominal span	-50 ÷ 50 mmH2O / 0 ÷ 50 mmH2O
Minimum span	-8 ÷ 8 mmH2O
Input maximum relative pressure	3000 mmH2O
Maximum differential pressure between the two inputs	3000 mmH2O
Accuracy of reading: range 0 ÷ 8 mmH2O and 0 ÷ -8 mmH2O range 8 ÷ 18 mmH2O and -8 ÷ -18 mmH2O range 18 ÷ 50 mmH2O and -18 ÷ -50 mmH2O	<4% F.S. ± 0.4 mmH2O ± 1 digit ± 0.8 mmH2O ± 1 digit ± 2 mmH2O ± 1 digit

ESA PT-II -100÷100 mmH2O (type E):

Nominal span	-100 ÷ 100 mmH2O / 0 ÷ 100 mmH2O
Minimum span	-15 ÷ 15 mmH2O
Input maximum relative pressure	3000 mmH2O
Maximum differential pressure between the two inputs	3000 mmH2O
Accuracy of reading: range 0 ÷ 10 mmH2O and 0 ÷ -10 mmH2O range 10 ÷ 25 mmH2O and -10 ÷ -25 mmH2O range 25 ÷ 100 mmH2O and -25 ÷ -100 mmH2O	<4% F.S. ± 0.5 mmH2O ± 1 digit ± 1 mmH2O ± 1 digit ± 4 mmH2O ± 1 digit

CAUTION: Operation of combustion equipment can be hazardous resulting in bodily injury or equipment damage. Each burner should be supervised by a combustion safeguard and only qualified personnel should install, make system adjustments and perform any required service.



ORDAN THERMAL PRODUCTS LTD
Combustion Equipment & Controls for Industry
21 Amber St # 9, Markham Ontario Canada L3R 4Z3
Tel: (905) 475-9292 Fax: (905) 475-3286
www.ordanthermal.com

NOTICE: PYRONICS practices a policy of continuous improvement in the design of its products. It reserves the right to change the specifications at any time without prior notice.

KEYBOARD DESCRIPTION

There are 2 groups of buttons:

- 1) The RAISE (↑) or LOWER buttons (↓).
- 2) (F) FUNCTION button.

The main functions of these buttons are shown in the following table:

OPERATION	MODE	DESCRIPTION
↑ or ↓	Automode	Displays scanning of all available quantities in automatic mode.
↑ F	Automode	Activates programming mode.
↑ or ↓	Program.	Displays scanning of available menus and in the menus the parameters to be set. When the values of the parameters are being changed, changes the values displayed on the lower display.
F	Program.	Gives access to the menu displayed. In the menus enables the change of the parameter displayed and then stores the current value.
↑ F	Program.	Returns to Automode. When the values of the parameters are being changed, exits from programming mode without storing.

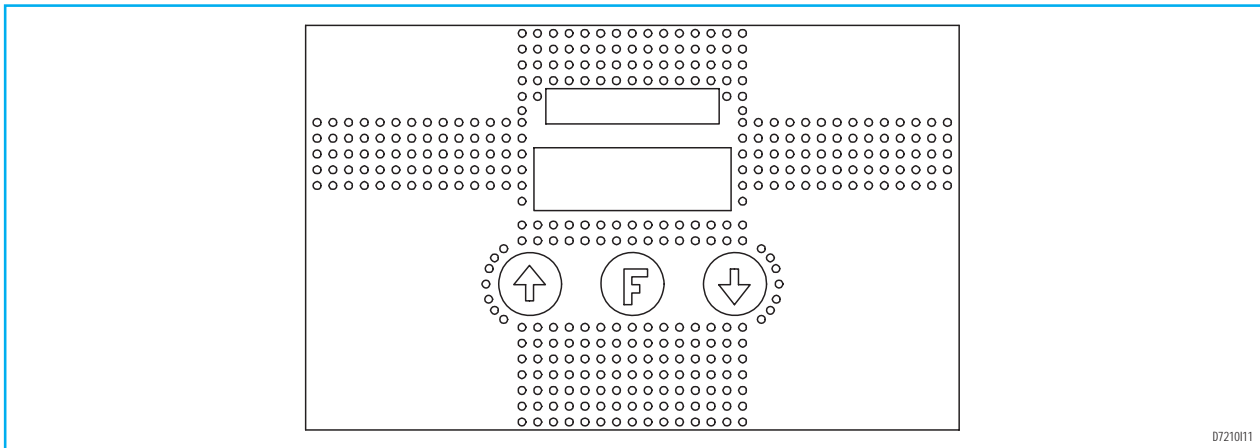

DESCRIPTION OF DISPLAY

There are two groups of displaying elements:

- 1) UPPER ALPHANUMERIC DISPLAY

In automode, it displays the name of the physical quantity measured by the instrument or the total flow rate value (Nm³/h); in programming mode displays the name of the current parameter.

- 2) 7 SEGMENT 4 DIGIT DISPLAY

In automode, it displays the physical quantity measured by the instrument, whereas in programming mode, it displays either the name of the selected menu or the value of the current parameter.

POWER UP

In this phase, the instrument identification is displayed (ESA-PT) together with the version number of software fitted. At that point the message "rel.se" appears on the upper display and the release number on the lower one. The message "dataerr." may appear on the

upper display if the instrument realizes that some programmed parameters have not been properly stored in the interior non volatile memory. If that is the case, it is necessary to contact our technical staff.

CAUTION: Operation of combustion equipment can be hazardous resulting in bodily injury or equipment damage. Each burner should be supervised by a combustion safeguard and only qualified personnel should install, make system adjustments and perform any required service.



ORDAN THERMAL PRODUCTS LTD
 Combustion Equipment & Controls for Industry
 21 Amber St # 9, Markham Ontario Canada L3R 4Z3
 Tel: (905) 475-9292 Fax: (905) 475-3286
www.ordanthermal.com

NOTICE: PYRONICS practices a policy of continuous improvement in the design of its products. It reserves the right to change the specifications at any time without prior notice.

AUTOMATIC MODE (Automode)

After the power up, if no errors have been made while storing data, the instrument automatically enters in the steady state displaying phase. By pressing the \uparrow or \downarrow buttons, the different displaying functions of the steady state mode are made available and the values of the physical quantities measured by the instrument are displayed: differential pressure, instant flow rate, total flow rate, fluid temperature, auxiliary input signal, fluid pressure, digital input status, transmitted signal, digital output. A default quantity may be selected,

which must be displayed first (see parameter "default"). For instance if you select temperature, even if the quantity of "default" is instant flow rate, the instrument will automatically switch from temperature to instant flow rate, after a couple of seconds (see parameter "t.show"). To return to temperature, press the \uparrow or \downarrow buttons once again. Furthermore it is possible to select which quantities to display and which quantities to hide as long as they are not useful for the application (see parameter "Display").

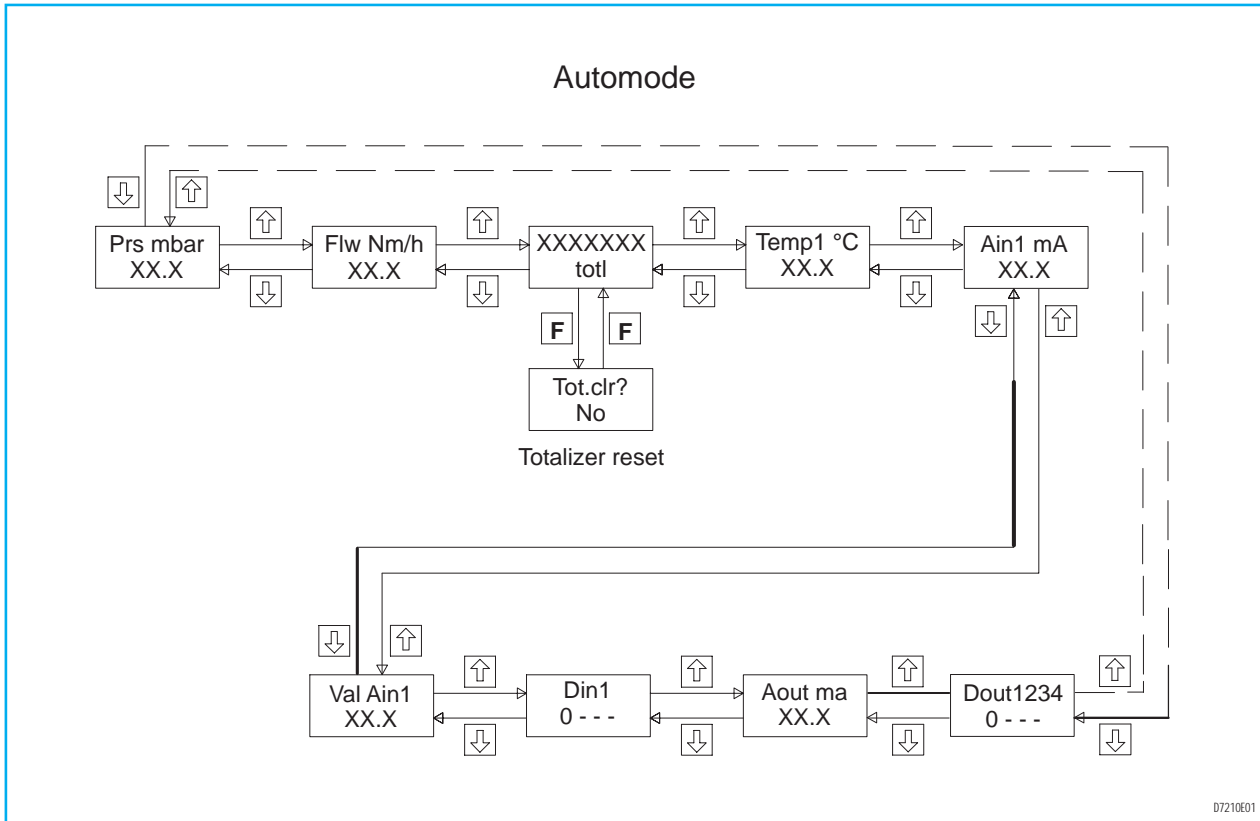

CAUTION: Operation of combustion equipment can be hazardous resulting in bodily injury or equipment damage. Each burner should be supervised by a combustion safeguard and only qualified personnel should install, make system adjustments and perform any required service.



ORDAN THERMAL PRODUCTS LTD
 Combustion Equipment & Controls for Industry
 21 Amber St # 9, Markham Ontario Canada L3R 4Z3
 Tel: (905) 475-9292 Fax: (905) 475-3286
www.ordanthermal.com

NOTICE: PYRONICS practices a policy of continuous improvement in the design of its products. It reserves the right to change the specifications at any time without prior notice.

OPERATION	LOWER DISPLAY	UPPER DISPLAY	DESCRIPTION
Supply	8888	ESA-PT	
None	r.888	Release	Software version
None	8888	Prs mbar	Displays differential pressure value (mbar or mmH2O or Pa or incWC)
↑ or ↓	8888	Flw Nm/h	Displays instant flow value (Nm ³ /h or cfm)
↑ or ↓	totl	88888888	Displays total flow rate value (Nm ³ /h or cfm)
↑ or ↓	8888	Temp1 'C	Displays fluid temperature value (°C or °F)
↑ or ↓	8888	Ain1 mA (*)	Displays value of received current (mA) in EXP-C
↑ or ↓	8888	Val Ain1	Displays fluid pressure value (mbar or mmH2O)
↑ or ↓	8---	Din1	Displays digital input status
↑ or ↓	8888	AOut1 mA	Displays value of transmitted current (mA)
↑ or ↓	8---	Dout1234 (*)	Displays the digital output status

(*): This parameter can be displayed only if the EXP-C expansion card is used.

FLOW RATE TOTALIZER

The instrument assesses the fluid consumption on the basis of the instant flow rate values taken one after the other. The total flow rate value appears on the upper display whereas the message "TotL". The maximum value equals either 99'999'999 Nm³/h or 99'999'999 cfm, according to the unit chosen for the displaying of flow. Resetting of the total flow rate value, only occurs if "Tot.res" is ON and after the resetting input coming via serial line, Din1 digital input (see parameter "Func Din1") or keyboard. In this case:

- Press the F button while the total flow rate is being displayed. The instrument displays "Tot.clr?" on the upper display corresponding to the totalizer resetting mode and "NO" on the lower display.

- While the message "Tot.clr?" is being displayed, press ↑ or ↓ until the message "YES" is displayed on the lower display.
- Press F to confirm the request for resetting. During this procedure the message "donE" appears on the lower display.

If the EXP.C expansion card is installed, ESA PT-II enables the Dout1 digital output when the value of totalized flow reaches the value set in the "Tot.Cont" parameter for the time set in the "Tot.Tmr" parameter. The digital output is enabled every time when the value of the totalizer overcomes the totalized flow corresponding to the previous enabling by the "Tot.Cont" value. Should you want to keep the digital output always enabled until the following resetting of the totalizer, you only have to set the "Tot.Tmr" parameter at zero.

CAUTION: Operation of combustion equipment can be hazardous resulting in bodily injury or equipment damage. Each burner should be supervised by a combustion safeguard and only qualified personnel should install, make system adjustments and perform any required service.



ORDAN THERMAL PRODUCTS LTD
Combustion Equipment & Controls for Industry
 21 Amber St # 9, Markham Ontario Canada L3R 4Z3
 Tel: (905) 475-9292 Fax: (905) 475-3286
www.ordanthermal.com

NOTICE: PYRONICS practices a policy of continuous improvement in the design of its products. It reserves the right to change the specifications at any time without prior notice.

PROGRAMMING MODE (Program.)

In Programming mode, all operating parameters can be set. The instruments are configured to the specifications of the plant or the preferences of the user. To access the programming mode of the configurable parameters, press the \uparrow and **F** buttons simultaneously from automode. The instrument will show the current functioning

mode displaying "Program." on the upper display and the name of the menu on the lower one. To leave the programming mode and return to the steady state mode press \uparrow and **F** simultaneously again; the message "Automode" will be displayed for a couple of seconds to indicate you are leaving the programming mode.

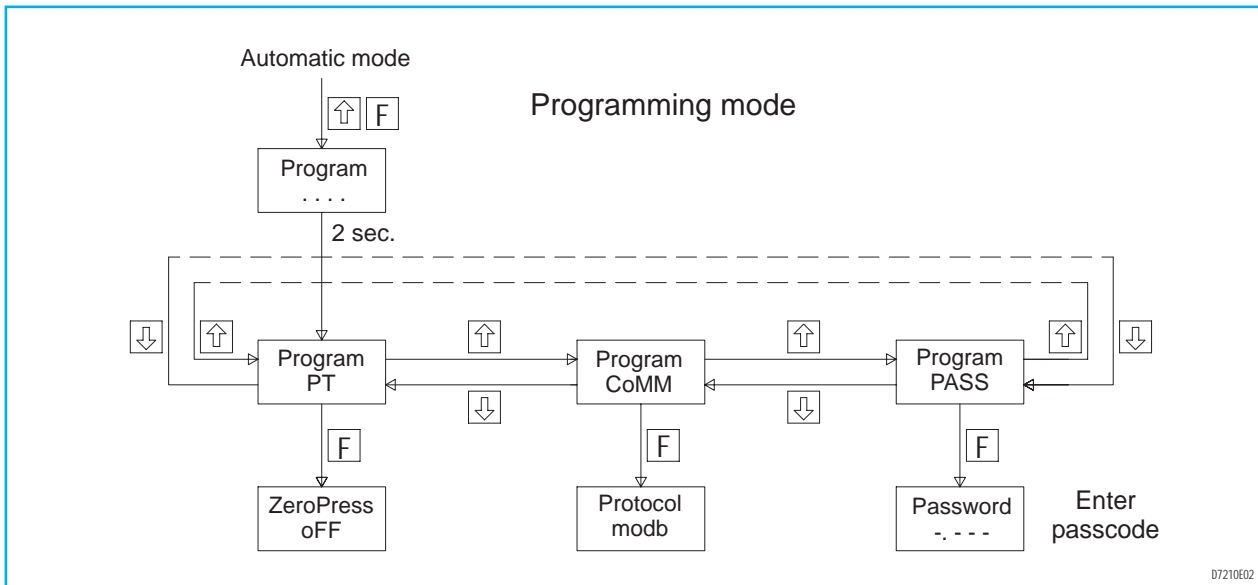

The following menus are available:

- **PT Menu:** contains all the parameters concerning the measurement and transmission of quantities, such as values of measurement of the element to assess, upper threshold of readings or transmitted signal setting.
- **Comm Menu:** this contains the parameters concerning serial communication.
- **Prot.Prg Menu:** contains parameters concerning the display of quantities, such as filtering setpoints, default quantity or reading resolution. The password "-AE-" gives access to this menu.
- **Hardware Menu:** contains the parameters concerning the hardware of the instrument, such as the type of TC1 thermocouple or the calibration of the transmitted analogue signal. The password "-CE-" gives access to this menu.

Use the \uparrow or \downarrow buttons to select the menus of your choice and confirm by pressing **F**. To leave the menu and return to programming mode, select the correct parameter and confirm by pressing **F**. Should you want to access either "Prot.prg" or "Hardware" menus, enter the passcode in "PASS" menu. Then, by pressing **F**, on the upper display the word "Password" appears: at this point the user may choose either a figure or a letter, using the \uparrow or \downarrow buttons, on one of the 4 digits of the lower display. The digit whose decimal point is flashing switches to the new data. Press **F** to choose another character on the subsequent digit. After entering the 4 digit passcode, which is displayed on the lower display, press **F** once again. If the passcode is correct, you automatically enter the corresponding menu. If you do not know the passcode or want to return to automatic mode, you only have to press \uparrow and **F** simultaneously.

CAUTION: Operation of combustion equipment can be hazardous resulting in bodily injury or equipment damage. Each burner should be supervised by a combustion safeguard and only qualified personnel should install, make system adjustments and perform any required service.



ORDAN THERMAL PRODUCTS LTD
 Combustion Equipment & Controls for Industry
 21 Amber St # 9, Markham Ontario Canada L3R 4Z3
 Tel: (905) 475-9292 Fax: (905) 475-3286
www.ordanthermal.com

NOTICE: PYRONICS practices a policy of continuous improvement in the design of its products. It reserves the right to change the specifications at any time without prior notice.

TO CHANGE PARAMETER:

To change parameter values:

- When the required parameter has been selected, by pressing the ↑ and ↓ keys, its name is shown in the upper display, whereas its value is shown in the lower display.
- Press F to enable the parameter to be changed: the message on the upper display starts flashing.
- Press the ↑ and ↓ buttons to either increase or decrease the value. If you have made a mistake or do not want to store the new value, remember that such changes will only remain effective until you are in the programming mode, when they will be overwritten by the stored program values. Hence you only have to exit

- from the programming mode (by pressing F and ↑ simultaneously) to prevent the new value from being stored.
- Press F to store the new value of the parameter in the memory; the message "done" will appear on the lower display for a couple of seconds if the new value has been correctly stored.
- Once the value has been stored, the message on the upper display stops flashing;
- Use the ↑ and ↓ buttons to select the parameter you now want to change or leave the menu or the programming mode.

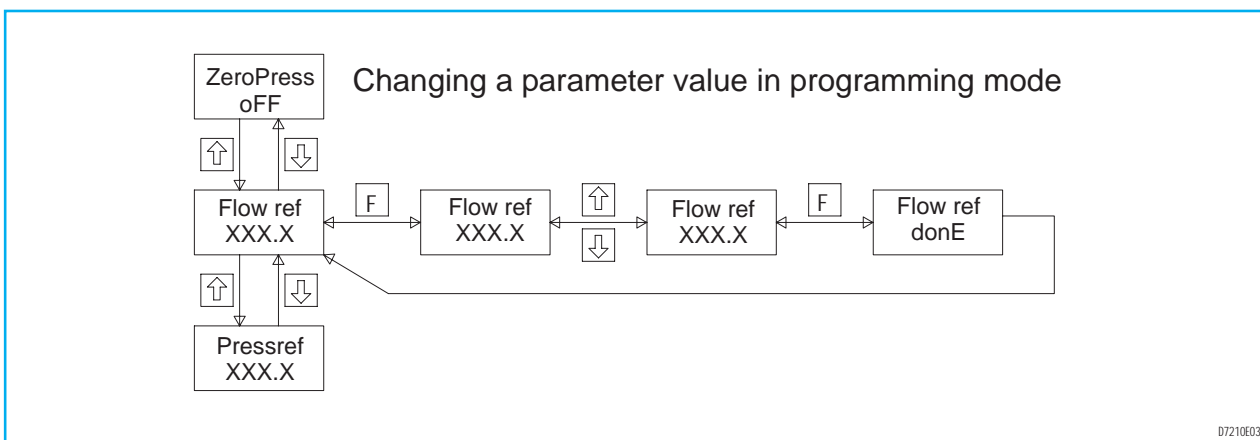

PT MENU

PARAMETER	UPPER DISPLAY	DEFAULT	MINIMUM VALUE	MAXIMUM VALUE
Compensation of zero pressure	ZeroPres	OFF	OFF	ON
Flow rate of reference (Nm ³ /h)	Flow ref	8888	0	6553
Differential pressure of reference (mbar or mmH2O)	Pressref	8888	-300	3000
Temperature of reference (°C)	Temp.ref	8888	0	700
Input pressure of reference (mbar or mmH2O)	Prsinref	0	0	3000
Lower threshold pressure (mbar or mmH2O)	Prs.Init	0	-300	3000
Increase of flow rate upper threshold (Nm ³ /h)	Flow inc	0	0	6553
Quantity associated with output Out1	Out1 sou	8888	FLOW	PRES
Output Out1 signal type	out1type	8888	d 0.0	r 4.0
Enabling/disabling of totaliser resetting	tot. res	ON	OFF	ON
Threshold of totalized flow for Dout1 enabling	Tot.Cont	0	0	99'999'999
Duration of Dout1 impulse (in seconds)	Tot.Tmr	0	0	10
Exit from PT Menu	Exit PT	YES	YES	YES

CAUTION: Operation of combustion equipment can be hazardous resulting in bodily injury or equipment damage. Each burner should be supervised by a combustion safeguard and only qualified personnel should install, make system adjustments and perform any required service.



ORDAN THERMAL PRODUCTS LTD
 Combustion Equipment & Controls for Industry
 21 Amber St # 9, Markham Ontario Canada L3R 4Z3
 Tel: (905) 475-9292 Fax: (905) 475-3286
 www.ordanthermal.com

NOTICE: PYRONICS practices a policy of continuous improvement in the design of its products. It reserves the right to change the specifications at any time without prior notice.

- **ZeroPres.:** corrects zero pressure via keybutton; this parameter allows automatic resetting of differential pressure readout to be executed; it is meant to field-compensate the changes of zero readout in the medium-long run. **Before starting, make sure ESA PT-II has been working for 15 minutes at least** (otherwise the lower display will show ERR2) **and that the tubes of the input pressure signal are disconnected.** This function does not appear if resetting through keybutton is not possible, that is when the "res. sou" parameter is neither Butt nor ALL. The instruments does not accept such function when the pressure read by the sensor is higher than 5 mbar (5 mmH2O for C, D and E versions) and lower than -5 mbar (-5 mmH2O for C, D and E versions).
- **Flowref:** sets the flow rate for the calculation of the measuring tools ; together with "Pressref", "Temp.ref", "PrsInref" and "Prs.Init", this parameter allows the instant and total flow rate to be calculated. Furthermore, if parameter "Out1 sou" is equal to FLOW, the value of "Flowref" plus the value of "Flowinc" becomes the value of reference for the current output Out1 upper threshold (20 mA). (See note No. 1)
- **Pressref:** sets the differential (or relative) pressure for the calculation of the measuring tools. Together with "Flowref", "Temp.ref", "PrsInref" and "Prs.Init", it allows the instant as well as total flow rate to be calculated. Furthermore, if parameter "Out1 sou" is equal to PRES, the value of "Pressref" becomes the value of reference for the current output Out1 upper threshold (20 mA) as compared with "Prs. Init". (See note No. 1)
- **Temp.ref:** sets the temperature of reference at which the calculation of the measuring tools was made. Together with "Flowref", "Press.ref", "PrsInref" and "Prs.Init", it allows the instant, total flow rate to be calculated and automatically temperature compensated. (See note No. 1)
- **PrsInref:** sets the pressure of reference at which the calculation of the measuring tools was made. Together with "Flowref", "Press.ref", "Temp.ref" and "Prs.Init", it allows the instant, total flow rate to be calculated and automatically pressure compensated. (See note No. 1)
- **Prs.Init:** sets the pressure value corresponding at lower threshold, where the value of flow rate is 0; together with "Flowref", "Pressref", "Temp.ref" and "PrsInref", it allows the instant, total flow rate to be calculated. Furthermore, if parameter "Out1 sou" is equal to PRES, the value of "Prs.Init" becomes the value of reference for the current output Out1 lower threshold (0 or 4mA). (See note No. 1)
- **Flw.Inc:** sets the flow rate value to add to "Flowref" when the value of the instant flow rate to transmit back is higher than the flow rate of reference. Furthermore, if the parameter "Out1 sou" is equal to FLOW, "Flowinc" plus "Flowref" becomes the value of refe-

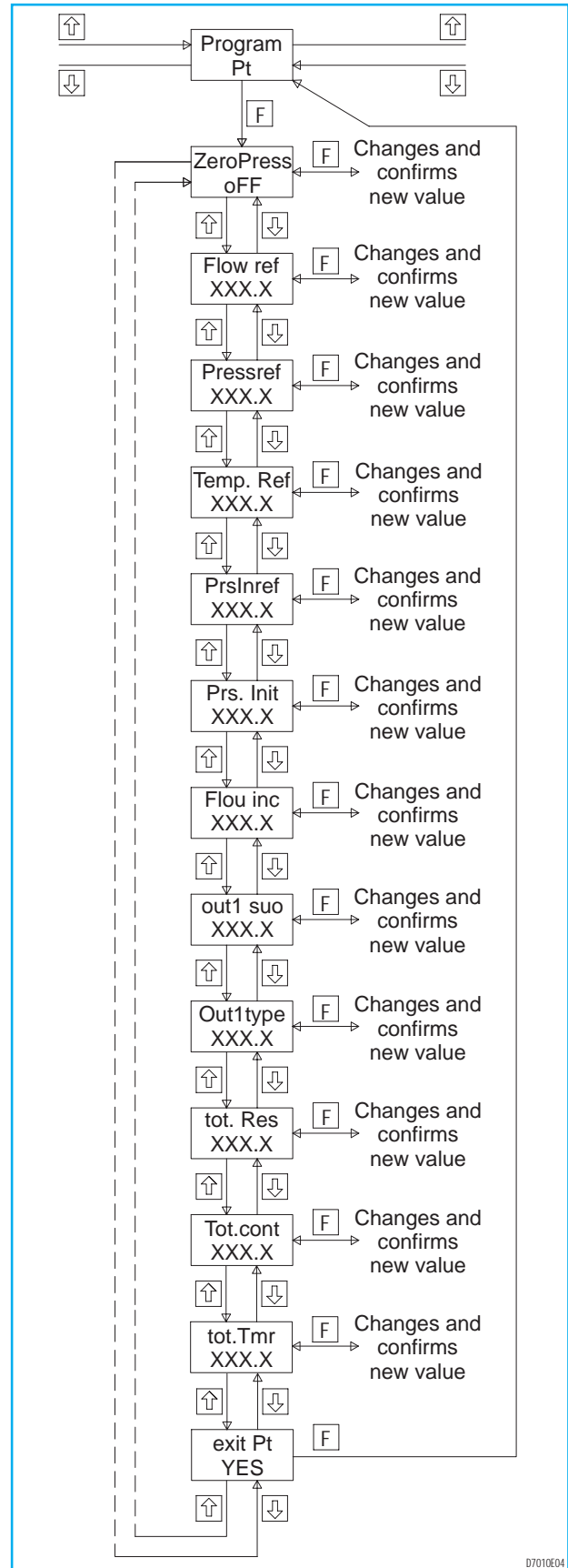

D7010E04

CAUTION: Operation of combustion equipment can be hazardous resulting in bodily injury or equipment damage. Each burner should be supervised by a combustion safeguard and only qualified personnel should install, make system adjustments and perform any required service.



ORDAN THERMAL PRODUCTS LTD
 Combustion Equipment & Controls for Industry
 21 Amber St # 9, Markham Ontario Canada L3R 4Z3
 Tel: (905) 475-9292 Fax: (905) 475-3286
 www.ordanthermal.com

NOTICE: PYRONICS practices a policy of continuous improvement in the design of its products. It reserves the right to change the specifications at any time without prior notice.

rence for the current output Out1 upper threshold (20mA). (See note No. 1)

- **Out1 sou:** selects the quantity associated with the current output Out1 signal: either proportional to the pressure that has been read (Pres) or proportional to instant flow rate (Flou).
- **out1type:** selection of the electrical input level of the current output signal Out1: 0÷20 mA direct (d 0.0), 4÷20 mA direct (d 4.0), 0÷20 mA reverse (r0.0), 4÷20 mA reverse (r 4.0), or 4÷20 mA with zero pressure at 12 mA (12.0) to be used only with output proportional to pressure for measures specular to zero.
- **tot.res.:** enables/disables totaliser resetting: ON is enabled; OFF is disabled.
- **Tot.cont:** setting of the totalized flow value to which the enabling of the Dout1 digital output must correspond for the time set in the parameter "Tot.Tmr". Moreover if "Tot.Tmr " equals zero, since

when the totalized flow overcomes "Tot.Cont" the Dout1 digital output remains enabled until the totalizer resetting.

- **Tot.Tmr:** setting of the duration (in seconds) of the enabling of the Dout1 digital output. If the value is set at zero, the Dout1 digital output remains enabled.
- **Exit PT:** exits from the menu PT, when required ; by pressing F the instrument displays the programming mode again.

Please remember that the choice of current output Out1 scale is subject to the quantity which is associated with it, therefore the instrument does not accept Out1type equal to 12.0 when Out1 sou is equal to Flou viceversa it does not accept Out1 sou equal to Flou when Out1type is equal to 12.0.

Note1: when ESA PT-II is used for some flow measure, the calculation values of the measuring element must be set in the "Flow ref" and "Flow inc" parameters in normalized cubic meters per hour (Nm³/h); in the "Pressref", "prsinref" and "Prs.init" parameters in millibar (mbar), and in the "Temp.ref" parameter in centigrade degrees (°C). Moreover in the "U.PRS.PRG" parameter it is necessary to select the mbar unit. When ESA PT-II is used as pressure transmitter, the reference values for the signal transmission can be set either in mbar or in mmH₂O, provided the measuring unit set in the "U.Prs.Prg." is respected.

QUANTITY	DIRECT CONVERSION	REVERSE CONVERSION
Flow	Nm ³ /h = cfm x 1,6990	cfm = Nm ³ /h x 0,5886
Pressure	mbar = mmH ₂ O x 0,09806	mmH ₂ O = mbar x 10,1974
Pressure	mbar = Pa x 0,01	Pa = mbar x 100
Pressure	mbar = incWC x 2,4884	incWC = mbar x 0,4018
Temperature	°C = 5/9 x (°F - 32)	°F = (9/5 x °C) + 32

CAUTION: Operation of combustion equipment can be hazardous resulting in bodily injury or equipment damage. Each burner should be supervised by a combustion safeguard and only qualified personnel should install, make system adjustments and perform any required service.



ORDAN THERMAL PRODUCTS LTD
 Combustion Equipment & Controls for Industry
 21 Amber St # 9, Markham Ontario Canada L3R 4Z3
 Tel: (905) 475-9292 Fax: (905) 475-3286
www.ordanthermal.com

NOTICE: PYRONICS practices a policy of continuous improvement in the design of its products. It reserves the right to change the specifications at any time without prior notice.

COMM MENU

PARAMETER	UPPER DISPLAY	DEFAULT	MINIMUM VALUE	MAXIMUM VALUE
Communication protocol display	Protocol	Modb	Modb	Modb
Serial communication address	Node No.	1	1	255
Serial communication speed	K baud	9.6	2.4	19.2
Data transfer resolution	Resolut.	Full	Int	Flnt
Serial communication timeout (sec.)	Ctimeout	0	0	255
Exit from COMM menu	Exit Comm	YES	YES	YES

- **Protocol:** displays serial communication protocol. The instrument communicates with a remote supervisor via Modbus RTU (Modb) protocol.
- **Node No.:** sets the serial address identifying the instrument in the network and must correspond to the address stored in the remote supervisor. No two instruments can have the same address in the network.
- **K baud:** selects the serial communication speed between instrument and supervisor. The speeds are: 2400 baud/s (2.4), 4800 baud/s (4.8), 9600 baud/s (9.6) and 19200 baud/s (19.2). The set speed correspond to the speed of the whole network.
- **Resolut.:** resolution of transmitted values in serial communication, corresponding to the one selected in the remote supervisor. Data can be transmitted either with decimal figures included (Full), only as entire values (Int) or with some parameters transmitted as entire and others with decimal figures included (Fint). For a more accurate description see the paragraph about serial communication.
- **Ctimeout:** setting of maximum delay (in seconds) before the instrument displays a Com Timeout alarm condition for lack of serial communication. By setting time 0, this alarm is disabled.
- **ExitComm:** exits from COMM menu; by pressing F, the instrument returns to programming mode.

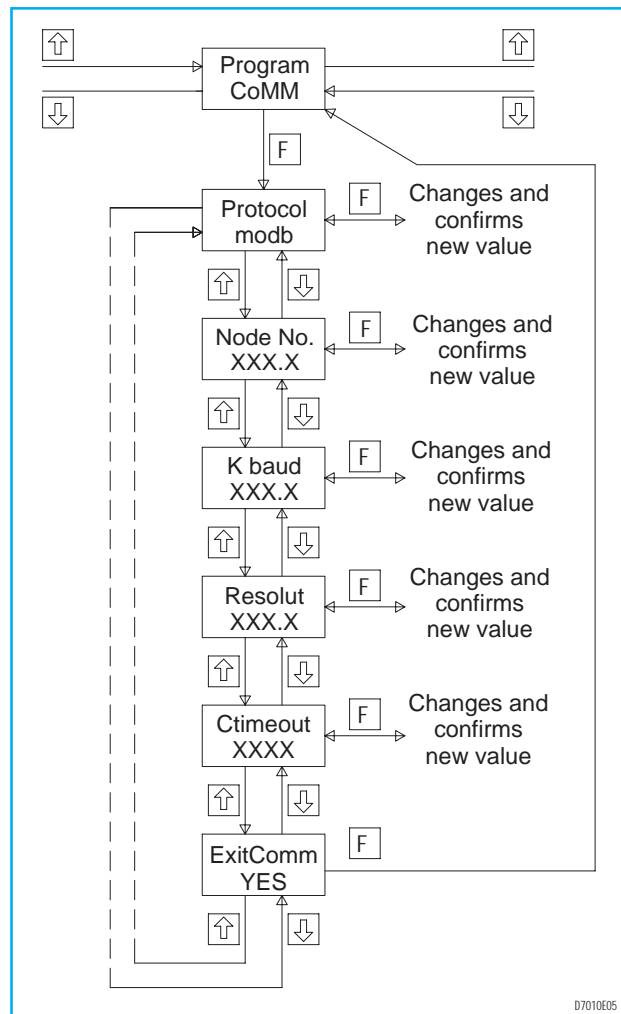

D7010E05

CAUTION: Operation of combustion equipment can be hazardous resulting in bodily injury or equipment damage. Each burner should be supervised by a combustion safeguard and only qualified personnel should install, make system adjustments and perform any required service.



ORDAN THERMAL PRODUCTS LTD
 Combustion Equipment & Controls for Industry
 21 Amber St # 9, Markham Ontario Canada L3R 4Z3
 Tel: (905) 475-9292 Fax: (905) 475-3286
 www.ordanthermal.com

NOTICE: PYRONICS practices a policy of continuous improvement in the design of its products. It reserves the right to change the specifications at any time without prior notice.

PROT.PRG MENU

PARAMETER	UPPER DISPLAY	DEFAULT	MINIMUM VALUE	MAXIMUM VALUE
Filtering on pressure values	P filter	8	2	20
Filtering on temperature values	T filter	3	1	3
Quantity displayed as default	Default	Flow	Pres	Out1
Enabling/disabling of automatic mode quantity display	Display	----	----	----
Enabling/disabling of access to menus in programming mode	Access	----	----	----
Resolution of pressure display	P resltn	.0	0.	.00
Enabling of zero pressure compensation	res. sou	butt	OFF	ALL
Minimum for pressure reading	P thresh	0.000	0.000	5.000
Display time of a quantity different from default (in seconds)	t.show.	20	1	255
Adjustment of display luminosity	brightns	3	1	7
Differential pressure value of ref. at 0° C	Press. 0C	8888	8888	8888
Differential pressure value of ref. at 0° C referred to Flow Inc	Prs.0inc	8888	8888	8888
Source of compensation temperature	T CmPSou	TC1	OFF	TC1
Compensation default temperature	Temp.Def	0	0	1300
Source of compensation pressure	P CmPSou	OFF	OFF	Ain1
Compensation default pressure	Pres.Def	0	0	999.9
Measuring unit for pressure displaying	U.PrsVis	mbar	mbar	Incw
Measuring unit for flow displaying	U.FlWVis	M3 h	M3 h	CFM
Measuring unit for temperature displaying	U.TempVis	C	C	F
Exit from PROT.PRG menu	Exit PrgP	YES	YES	YES

- **P filter:** sets the software filtering function of pressure signal. The higher this parameter, the smaller the influence of slight, instant changes in differential pressure as against the value displayed. Should a low value be set, the pressure value displayed could change rapidly.
- **T filter:** sets the software filtering function of the temperature signal. The higher this parameter, the smaller the influence of small, instant changes in the TC1 input value on the temperature value displayed. Should a low value be set, the temperature value displayed could change rapidly
- **default:** defines the physical quantity to be displayed as default in automatic mode. That means that by selecting a different physical quantity, through the ↑ and ↓ buttons, at the end of the time

set in parameter "t.show", the instrument automatically displays the quantity selected as default. Furthermore when powered, the instrument automatically displays the quantity of default. Possibilities available: differential pressure (Pres); instant flow rate (Flou), total flow rate (tott); fluid temperature (Tem1), current input of optional card (Ain1), Fluid pressure (Vain), digital input (Din), current output (Out1) or last quantity selected by the user through ↑ and ↓ (rand).

- **Display:** selects the quantities to automatically display. When entering this menu you get in a sub-menu where all quantities are displayed one after the other and it is possible to either enable (YES) or disable (NO) the display of each of them. This parameter is meant to limit the range to quantities which are relevant to the

CAUTION: Operation of combustion equipment can be hazardous resulting in bodily injury or equipment damage. Each burner should be supervised by a combustion safeguard and only qualified personnel should install, make system adjustments and perform any required service.



ORDAN THERMAL PRODUCTS LTD
 Combustion Equipment & Controls for Industry
 21 Amber St # 9, Markham Ontario Canada L3R 4Z3
 Tel: (905) 475-9292 Fax: (905) 475-3286
www.ordanthermal.com

NOTICE: PYRONICS practices a policy of continuous improvement in the design of its products. It reserves the right to change the specifications at any time without prior notice.

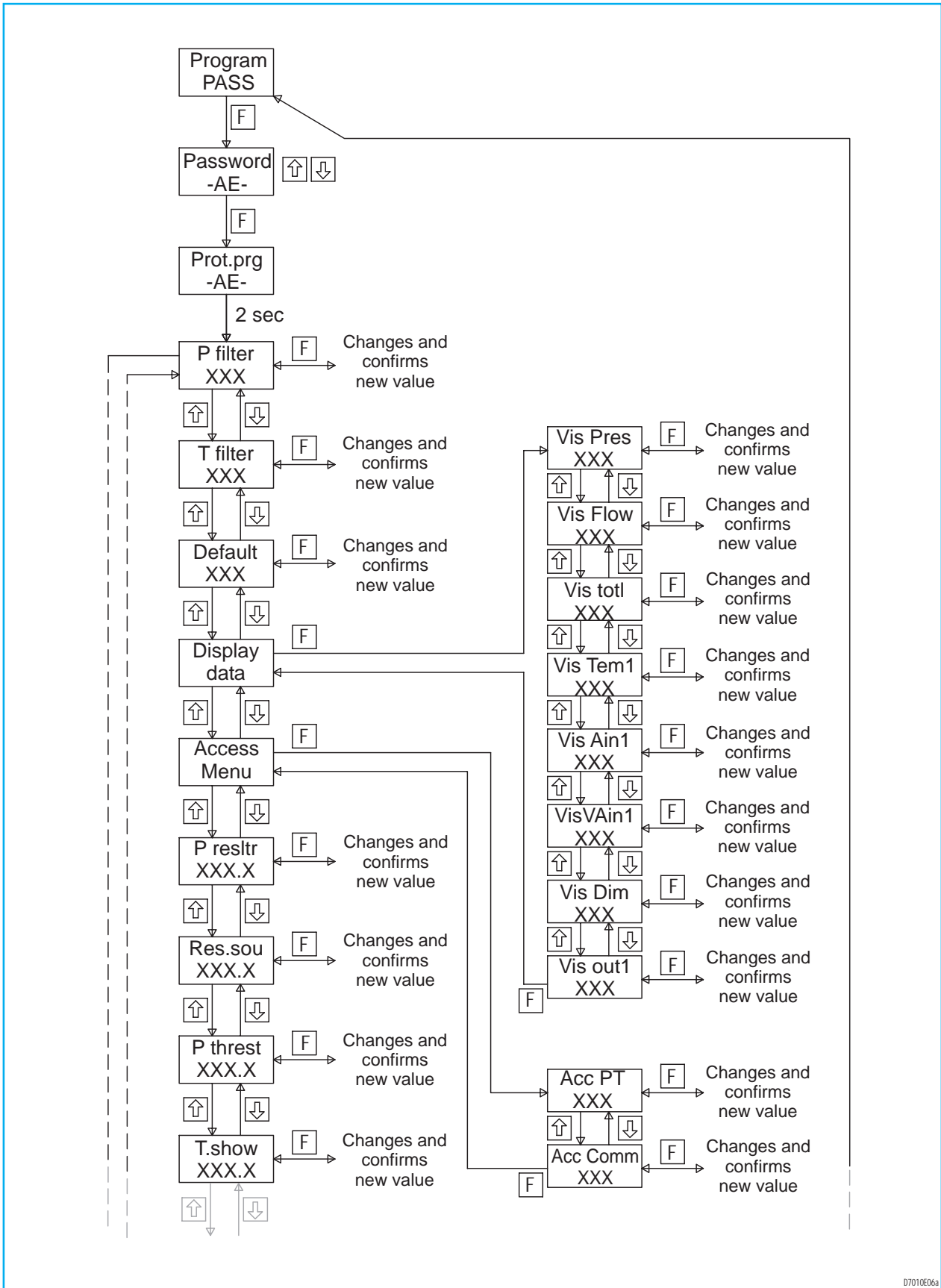

D7010E06a

CAUTION: Operation of combustion equipment can be hazardous resulting in bodily injury or equipment damage. Each burner should be supervised by a combustion safeguard and only qualified personnel should install, make system adjustments and perform any required service.



ORDAN THERMAL PRODUCTS LTD
 Combustion Equipment & Controls for Industry
 21 Amber St # 9, Markham Ontario Canada L3R 4Z3
 Tel: (905) 475-9292 Fax: (905) 475-3286
 www.ordanthermal.com

NOTICE: PYRONICS practices a policy of continuous improvement in the design of its products. It reserves the right to change the specifications at any time without prior notice.

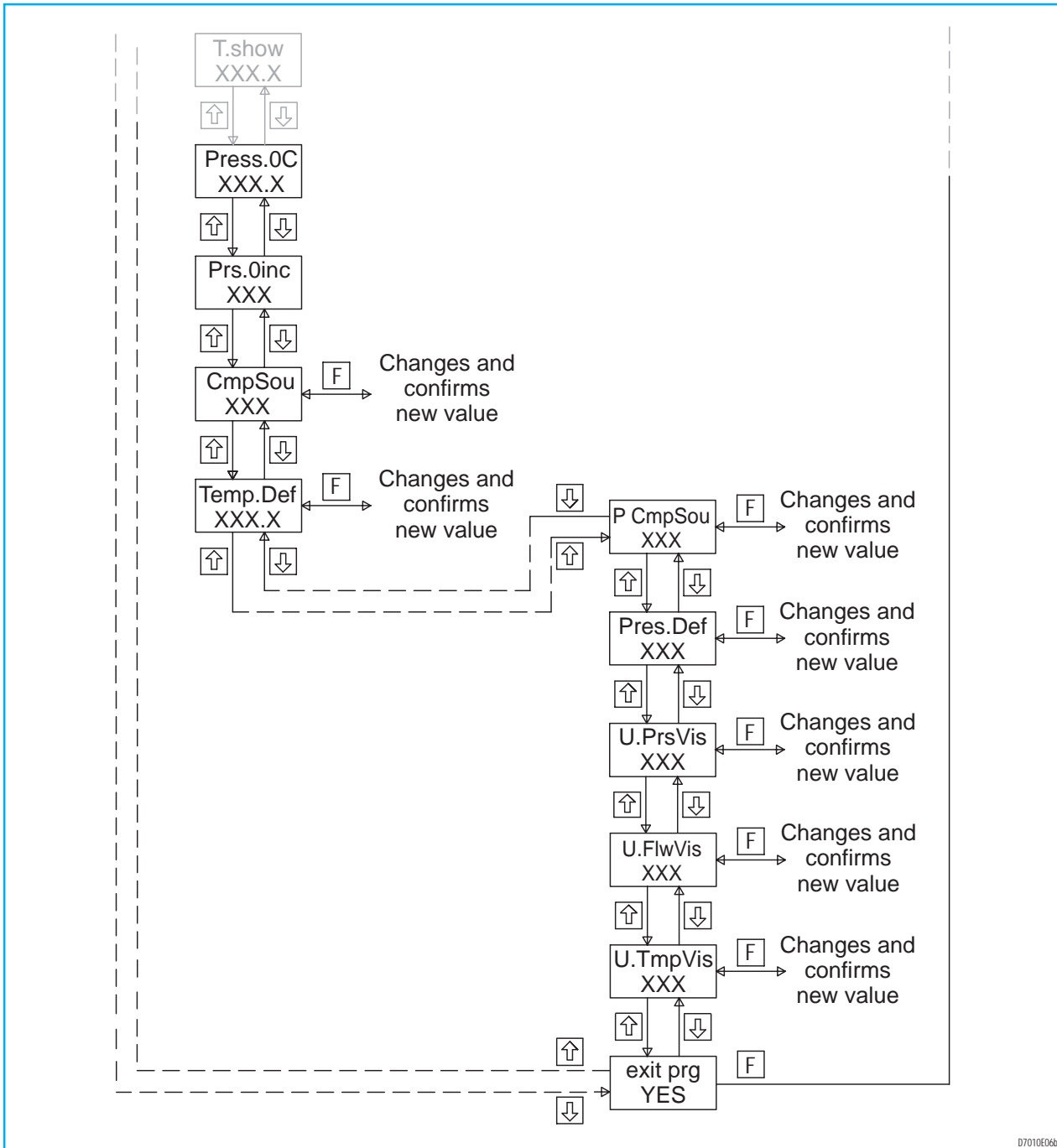

D7010E06b

specific application

- **Access:** enables access to menus in programming mode. When entering this parameter you get into a sub-menu where all menus of programming mode are displayed one after the other and for each of them it is possible to either enable (YES) or disable (NO) them. This parameter is meant to prevent unauthorized users from accessing the configuration parameters.
- **P resltn:** defines the displaying resolution of the input differen-

tial pressure, choosing either between integer resolution (0.) a decimal resolution (0.0) or centesimal resolution (0.00).

- **res. sou:** selects the zero pressure compensation. It may be achieved from keyboard accessing the parameter "ZeroPress" (butt), from digital input Din1 (Ext), from serial line (Ser), from both keyboard, digital input and serial line (All), or zero pressure correction not enabled (Off).
- **P thresh:** sets the minimum input differential pressure; pressure

CAUTION: Operation of combustion equipment can be hazardous resulting in bodily injury or equipment damage. Each burner should be supervised by a combustion safeguard and only qualified personnel should install, make system adjustments and perform any required service.



ORDAN THERMAL PRODUCTS LTD
 Combustion Equipment & Controls for Industry
 21 Amber St # 9, Markham Ontario Canada L3R 4Z3
 Tel: (905) 475-9292 Fax: (905) 475-3286
 www.ordanthermal.com

NOTICE: PYRONICS practices a policy of continuous improvement in the design of its products. It reserves the right to change the specifications at any time without prior notice.

measuring is not possible below that value hence the reading is considered = "Prs.Init". The effect of this parameter results both over and below the "Prs.Init" value, resulting in a non reading range.

- **t.showt.**: sets the displaying time (in seconds) in automode of a quantity different from the default quantity. After this time the instrument automatically displays the default quantity. If Rand is set as default, the time which has been set has no effect.
- **brightns**: sets the index of luminosity of the displays. 1 is the maximum value corresponding to the maximum power absorption.
- **Press.OC**: displays the differential pressure value of reference assessed by the instrument at 0 °C. It is a displaying parameter hence it is not user configurable and may not be changed.
- **Prs.Oinc**: displays the differential pressure value of reference assessed by the instrument at 0 °C taking into account any possible increase in the flow rate value of reference. It is a displaying parameter hence it is not user configurable and may not be changed.
- **T CmpSou**: selects the temperature signal used for temperature compensation of instant flow rate. There are several opportunities: TC1 (TC1) input temperature value, temperature value from serial line or from parameter "Tem.Def" (SEr.D) or temperature compensation disabled (OFF). When the second opportunity is selected, the instrument recurs to the value set in "Temp.Def" until a new value is communicated from serial line. If a Com timeout alarm occurs, the instrument always uses the value set in "Temp.Def" until communication is resumed.
- **Temp.Def**: sets the default temperature value, used for temperature compensation when "T CmpSou" is equal to "SEr.D". This value set equal to input temperature at measuring tool in steady state mode and allows for compensation of the instant flow rate value in case of lack of thermocouple connected in TC1.
- **P CmpSou**: selects the pressure signal used for pressure compensation of instant flow rate. Choice is between: input Ain1 pressure valued on expansion card EXP-C (Ain1), pressure value from serial line or from parameter "Pres.Def" (SEr.D) or pressure compensation disabled (OFF). When the second opportunity is chosen, the instrument recurs to the value set in "Pres.Def" until a new value is communicated from serial line. If a Com timeout alarm occurs, the instrument always uses the value set in "Pres.Def" until communication is resumed.
- **Pres.Def**: sets the default pressure value used for pressure compensation when "P CmpSou" is equal to "SEr.D". This value is set equal to input fluid pressure at measuring tool in steady state mode and allows for instant flow rate compensation in case of lack of pressure transmitter connected in the Ain1 input of the EXP-C optional card.
- **U.PrsVis**: selection of the measuring unit for the pressure displaying in automatic mode. The choice may be done among the following units: millibars (mbar), millimeters of water column (mmH2O), pascal (pa) or inches of water column.
- **U.FlWVis**: selection of the measuring unit for the instant flow and of the totalized flow in automatic mode, choosing between either normalised cubic meters per hour (Nm3/h) or cubic feet per minute (cfm).
- **U.TmpVis**: selection of the measuring unit for the temperature displaying in automatic mode, choosing between either Centigrade degrees (°C) or Fahrenheit degrees (°F).
- **ExitPrgP**: exits from "ProtPrg"; if configured, by pressing F, it displays the programming mode again.

CAUTION: Operation of combustion equipment can be hazardous resulting in bodily injury or equipment damage. Each burner should be supervised by a combustion safeguard and only qualified personnel should install, make system adjustments and perform any required service.



ORDAN THERMAL PRODUCTS LTD
 Combustion Equipment & Controls for Industry
 21 Amber St # 9, Markham Ontario Canada L3R 4Z3
 Tel: (905) 475-9292 Fax: (905) 475-3286
www.ordanthermal.com

NOTICE: PYRONICS practices a policy of continuous improvement in the design of its products. It reserves the right to change the specifications at any time without prior notice.

HARDWARE MENU

PARAMETER	UPPER DISPLAY	DEFAULT	MINIMUM VALUE	MAXIMUM VALUE
Presence of expansion card	HWR EXP	no	no	EXPC.
Thermocouple type connected in TC1 input	TC1 type	J	J	K
Offset on TC1 thermocouple readout (in °C)	TC1 ofst	0	-50	50
Calibration lower threshold current output Out1	Out1mALo	8888	8888	8888
Calibration upper threshold current output Out1	Out1mAHi	8888	8888	8888
Type current input Ain1 signal	Ai1 type (*)	0.0	0.0	4.0
Numeric value corresponding to input Ain1 lower threshold	Ai1valLo (*)	0.0	-999.9	999.9
Numeric value corresponding to input Ain1 upper threshold	Ai1valHI (*)	0.0	-999.9	999.9
Digital Din1 input function	Func Di1	ZE.Pr	ZE.Pr	Tot.r
Type of relative input pressure signal	Pres.In	Pos	Pos	Neg
Measuring unit of pressure used while programming	U.PrsPrg	Mbar	Mbar	Mh2o
By-pass value of pressure filtering	Delta Fr	600	0	4000
Exit from HARDWARE Menu	Exit hrw	YES	YES	YES

(*): Parameters available only with expansion card and if C.EXP is selected in parameter "HWR EXP".

- **HWR EXP:** selects the expansion card. The parameter must be set equal to EXPC when the card is installed, in order to enable the relative functions. By selecting Drim, some functions which are not referred to ESA PT-II are enabled, hence it must not be selected.
- **TC1 type:** selects the thermocouple type connected in TC1 input, choosing either between J (Tc J) with reading ranging from 0 to 800 °C or K (Tc K) ranging from 0 to 1250 °C.
- **TC1 ofst:** selects the offset (in °C) to be added to the temperature value read by the TC1 thermocouple input to correct possible reading mistakes.
- **Out1mALo:** calibrates current output OUT1 signal at lower threshold; this function allows for correction of analog signal transmission mistakes. When the parameter is being changed, the instrument activates the relative output at lower threshold and by pressing \uparrow and \downarrow , the numeric value displayed is modified until the correct output is reached; afterwards confirmation is necessary to store the new calibration. The numeric value displayed is not directly proportional to the transmitted current value hence it is necessary to decrease it in order to increase the output value or viceversa. To perform accurate calibration it is necessary to first correct the upper threshold value (parameter Out1mAHi) and then the lower threshold value.
- **Out1mAHi:** calibrates current output OUT1 signal at upper threshold; this function allows for correction of analog signal transmission mistakes. When the parameter is being changed, the instrument activates the relative output at upper threshold and by pressing \uparrow and \downarrow , the numeric value displayed is modified until the correct output is reached; afterwards confirmation is necessary to store the new calibration. The numeric value displayed is not directly proportional to the transmitted current value hence it is necessary to decrease it in order to increase the output value or viceversa.
- **Ai1 type:** selects the Ain1 input signal scale on EXP-C expansion card. Choice is between 0÷20 mA (0.0) and 4÷20 mA (4.0).
- **Ai1valLo:** sets the numeric value corresponding to lower threshold of Ain1 input signal. This value must correspond to fluid pressure to which the remote transmitter transmits the lower threshold signal.
- **Ai1valHI:** sets the numeric value corresponding to upper threshold of Ain1 input signal. This value must correspond to fluid pressure to which the remote transmitter transmits the upper threshold signal (20 mA).
- **FuncDi1:** selects the Din1 digital input function, choosing if either the signal must enable the automatic zero resetting of the differential pressure reading (ZE.Pr) or zero the total flow rate value (Tot.r).

CAUTION: Operation of combustion equipment can be hazardous resulting in bodily injury or equipment damage. Each burner should be supervised by a combustion safeguard and only qualified personnel should install, make system adjustments and perform any required service.



ORDAN THERMAL PRODUCTS LTD
 Combustion Equipment & Controls for Industry
 21 Amber St # 9, Markham Ontario Canada L3R 4Z3
 Tel: (905) 475-9292 Fax: (905) 475-3286
 www.ordanthermal.com

NOTICE: PYRONICS practices a policy of continuous improvement in the design of its products. It reserves the right to change the specifications at any time without prior notice.

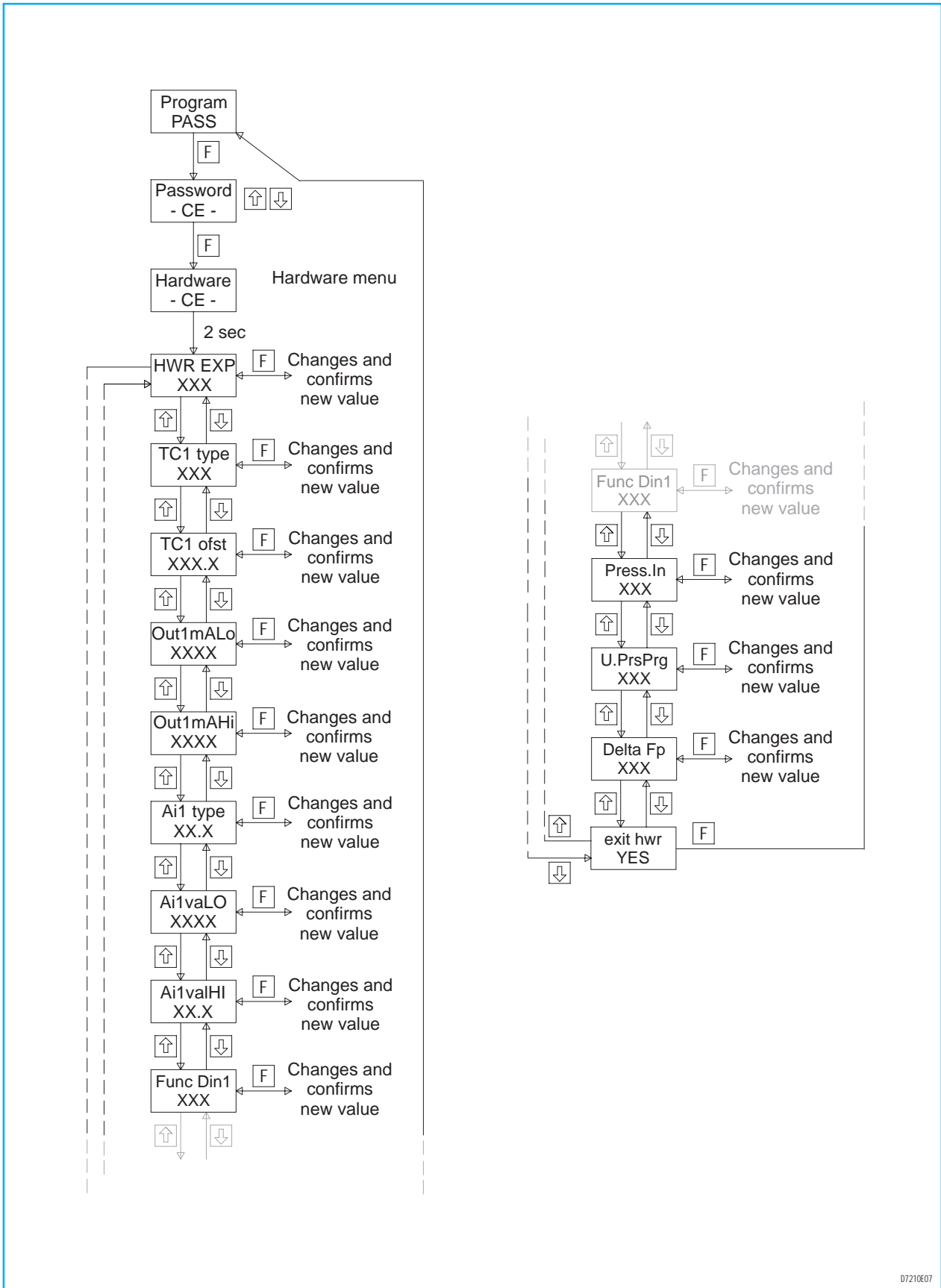

D7210E07

CAUTION: Operation of combustion equipment can be hazardous resulting in bodily injury or equipment damage. Each burner should be supervised by a combustion safeguard and only qualified personnel should install, make system adjustments and perform any required service.



ORDAN THERMAL PRODUCTS LTD
 Combustion Equipment & Controls for Industry
 21 Amber St # 9, Markham Ontario Canada L3R 4Z3
 Tel: (905) 475-9292 Fax: (905) 475-3286
 www.ordanthermal.com

NOTICE: PYRONICS practices a policy of continuous improvement in the design of its products. It reserves the right to change the specifications at any time without prior notice.

- **Pres.In:** selection of the pressure input to which the relative pressure signal has been connected, choosing between either the positive input (pos), or negative one (neg). The second case occurs when you have to read negative pressures with instruments such as A and B. By setting "Pres.In" at NEG, the device displays the negative pressure measuring.
- **U.PresPrg:** selection of the pressure measuring unit used for the "Pressref", "Prsinref" and "Prs.init" parameter setting in programming mode. The choice is between either millibar (mbar) or millimeters of water column (mmH2O), bearing in mind what has been said in "Note 1" described in PT menu.
- **Delta Fp:** selections of a by-pass value of the pressure filtering, meant to allow for a rapid reading response as against a wide change in input signal even if filtering is good. It is important to know that the numeric value displayed is directly proportional to the sensor range, hence by increasing this value the area around the measure where filtering defined in the "Pfilter" parameter is active is increased.
- **Exit hrw:** exits from HARDWARE menu; by pressing F the instrument returns to programming mode.

DIN1 DIGITAL INPUT

ESA PT-II is equipped with a digital input (Din1 input), to whom several functions can be associated via the parameter "Func Di1". This input must be void of current signals. To start the selected control, the Din1 digital input must stay active for 10 seconds at least and not active for further 5 seconds. The controls available are:

- Remote control for flow rate totaliser resetting: enables the resetting of the total flow rate value only if parameter "Tot.res" is ON. During this phase, the message "Tot.clear" flashes on the upper display.
- Remote control for zero pressure correction: enables the automatic resetting of the differential pressure reading only if enabled in

"res.sou". This function is meant to field-compensate the changes in zero reading in the medium-long run. Before proceeding further, **it is necessary to make sure ESA PT-II has been powered for the last 15 minutes at least** (otherwise the message ERR2 appears on the lower display) **and that the tubes of the input pressure signal are disconnected**. During this phase the message "ext.zero" flashes on the upper display. The instrument does not accept this control when the pressure read by the sensor is higher than 5 mbar (5 mmH2O for C, D and E versions) and lower than - 5 mbar (-5 mmH2O for C, D and E versions).

SERIAL COMMUNICATION

ESA PT-II is equipped with a digital communication interface to communicate with a PC, PLC or remote supervisor. Through the exchange of data and controls, supervision and control of the instrument are achieved. The hardware interface installed is a two-wire RS485 interface allowing up to 32 units to be connected coming from the same line. By means of adequate signal repeaters up to 254 units can be connected if required. The communication protocol is MODBUS-RTU

and the instrument is a slave device only responding after receiving a request from the master. 8-bit transmitted data, no parity and 1 stop bit; communication speed can be selected: 2400; 4800; 9600 or 19200 Baud/s. No unit connected to the same network can have the same address. ESA PT-II accepts the following requests from the supervisor:

MODBUS-RTU FUNCTION CODE	TYPE OF REQUEST	MAX N. OF WORDS FOR EACH COMMUNICATION
03	reading of n. words	25
06	writing of one word	1
16	writing of n. words	10

CAUTION: Operation of combustion equipment can be hazardous resulting in bodily injury or equipment damage. Each burner should be supervised by a combustion safeguard and only qualified personnel should install, make system adjustments and perform any required service.



ORDAN THERMAL PRODUCTS LTD
 Combustion Equipment & Controls for Industry
 21 Amber St # 9, Markham Ontario Canada L3R 4Z3
 Tel: (905) 475-9292 Fax: (905) 475-3286
www.ordanthermal.com

NOTICE: PYRONICS practices a policy of continuous improvement in the design of its products. It reserves the right to change the specifications at any time without prior notice.

The parameter values are transmitted as "signed", except if differently specified, and using one word (16 bits) for datum, the available values range from -32767 to 32767. In order to have greatest accuracy of data, the following opportunities can be chosen which best suit the application:

- **FULL**: all data are transmitted with their decimal or centesimal figure, respecting the parameter resolution. As for the differential pressure read, the resolution set for automode is respected. In this mode values up to 32767 can be transmitted, hence the instant flow rate, the flow rate of reference and the flow rate increase cannot be greater than 3276 Nm³/h (with one decimal figure).
- **INT**: all data are transmitted with no decimal figure, because all figures after the point are not taken into account. In this mode

the flow rate of reference and the flow rate increase may be transmitted with values up to 6530 Nm³/h whereas the instant flow rate may be transmitted with values up to 32760 Nm³/h.

- **FINT**: all data are transmitted with their decimal or centesimal figure, respecting the parameter resolution (as for FULL), except for instant flow rate values, flow rate of reference and flow rate increase which are transmitted as in INT. This mode allows for the serial transmission in applications where there are slight differential pressures (for instance decimal figures) and abundant flow rate.

The total flow rate value, unlike other parameters, is transmitted as "unsigned" in two words, the most significant in the 0 address and the least significant in the 1 address. This value may be read as "long" in the 0 address, or can be obtained as follows:

$$\text{Total flow rate} = (\text{address value 0} \times 65536) + \text{address value 1}.$$

Modbus addresses of the read quantities and of parameters of ESA PT-II, transmitted with FULL resolution are listed below. For serial transmission with other resolutions, please check what has been said previously.

AUTOMATIC MODE

PARAMETER	DESCRIPTION	DEC. POINTS	READ/WRITE	DEC. ADDRESS	VALUES
Prs mbar	instant differential pressure	1 o 2 (*)	R	02	- 32767 ÷ 32767
Flw Nm/h	Instant flow	1	R	03 unsigned	0 ÷ 65536
Totl	Totalized flow	0	R	00 (high) 01 (low) unsigned	0 ÷ 65536 0 ÷ 65536
Temp1 °C	TC1 input instant temperature	0	R	04	-100 ÷ 1300
Ain1 mA	current Ain1 input signal	1	R	11	0 ÷ 300
Val Ain1	relative value at Ain1 input	1	R	16	-9999 ÷ 9999
Din1	Din1 digital input state	0	R	05	0 ÷ 1
AOut1 mA	current Aout1 output signal	1	R	06	0 ÷ 300

(*): the decimal values transmitted are for the displaying resolution selected for automode (parameter "P reslt")

PROGRAMMING MODE - PT MENU

PARAMETER	DESCRIPTION	DEC. POINTS	READ/WRITE	DEC. ADDRESS	VALUES
Flow ref	Reference flow	1	R/W	127 unsigned	0 ÷ 65536
Press ref	Reference differential pressure	1	R/W	128	-3000 ÷ 30000
temp ref	Fluid temperature of reference	1	R/W	129	0 ÷ 7000

CAUTION: Operation of combustion equipment can be hazardous resulting in bodily injury or equipment damage. Each burner should be supervised by a combustion safeguard and only qualified personnel should install, make system adjustments and perform any required service.



ORDAN THERMAL PRODUCTS LTD
Combustion Equipment & Controls for Industry
21 Amber St # 9, Markham Ontario Canada L3R 4Z3
Tel: (905) 475-9292 Fax: (905) 475-3286
www.ordanthermal.com

NOTICE: PYRONICS practices a policy of continuous improvement in the design of its products. It reserves the right to change the specifications at any time without prior notice.

Prslnref	Input reference pressure	1	R/W	153	0 ÷ 30000
Prs init	Lower threshold pressure	1	R/W	130	-3000 ÷ 30000
Flou inc	Increase of flow electrical low input level	1	R/W	131 unsigned	0 ÷ 65536
out1 Sou	Quantity associated with Out1 output	0	R/W	200	0 Flow 1 Pres
out1type	Type of Out1 output signal	0	R/W	201	0 d 0.0 1 d 4.0 2 12.0 3 r 0.0 4 r 4.0
Tot res	Enabling/disabling of zero totaliser resetting	0	R/W	202	0 OFF 1 On
Tot.Cont	Value of totalized flow for Do1 digital output	0	R/W	171 (high) 172 (low) unsigned	0 ÷ 65536 0 ÷ 65536
Tot_tmr	Duration of impulse on Do1 digital output	1	R/W	173	0 ÷ 100

PROGRAMMING - COMM MENU

PARAMETER	DESCRIPTION	DEC. POINTS	READ/WRITE	DEC. ADDRESS	VALUES
Protocol	Communication protocol	0	R	217	0 Modbus
Node No.	Serial communication address	0	R/W	214	1 ÷ 255
K baud	Serial communication speed (*)	0	R/W	215	0 2.4 1 4.8 2 9.6 3 19.2
resolut	Trasmitted data resolution	0	R/W	216	0 Int 1 Fint 2 Full
Ctimeout	Communication timeout	0	R/W	170	0 ÷ 255

(*): The new communication speed, selected via serial communication, is only accepted at next power up.

CAUTION: Operation of combustion equipment can be hazardous resulting in bodily injury or equipment damage. Each burner should be supervised by a combustion safeguard and only qualified personnel should install, make system adjustments and perform any required service.



ORDAN THERMAL PRODUCTS LTD
 Combustion Equipment & Controls for Industry
 21 Amber St # 9, Markham Ontario Canada L3R 4Z3
 Tel: (905) 475-9292 Fax: (905) 475-3286
 www.ordanthermal.com

NOTICE: PYRONICS practices a policy of continuous improvement in the design of its products. It reserves the right to change the specifications at any time without prior notice.

PROGRAMMING MODE - PROT.PRG MENU

PARAMETER	DESCRIPTION	DEC. POINTS	READ/WRITE	DEC. ADDRESS	VALUES	
Pfilter	Filter on pressure reading	0	R/W	207	2 ÷ 20	
Tfilter	Filter on temperature reading	0	R/W	221	1 ÷ 3	
Default	Default quantity	0	R/W	204	0	pres
					1	flou
					2	totl
					3	tem1
					9	Ain1
					10	VAin
					11	Din1
					12	Out1
					15	rand
Vis Pres	Pressure displaying enabling	0	R/W	220 (bit0)	0	no
					1	YES
Vis Flow	Flow displaying enabling	0	R/W	220 (bit1)	0	no
					1	YES
Vis Totl	Totl displaying enabling	0	R/W	220 (bit2)	0	no
					1	YES
Vis Tem1	Tem1 displaying enabling	0	R/W	220 (bit3)	0	no
					1	YES
Vis Ain1	Ain1 mA displaying enabling	0	R/W	220 (bit9)	0	no
					1	YES
VisVAin1	Val Ain1 displaying enabling	0	R/W	220 (bit10)	0	no
					1	YES
Vis Din	Din1 displaying enabling	0	R/W	220 (bit11)	0	no
					1	YES
Vis out1	Aout1 mA displaying enabling	0	R/W	220 (bit12)	0	no
					1	YES
Vis dout	Dout displaying enabling	0	R/W	220 (bit14)	0	no
					1	YES
Acc PT	PT menu access enabling	0	R/W	219 (bit1)	0	no
					1	YES
Acc Comm	Comm menu access enabling	0	R/W	219 (bit2)	0	no
					1	YES
Presltr	Resolution of pressure displaying	0	R/W	208	0	0.
					1	.0
					2	.00

CAUTION: Operation of combustion equipment can be hazardous resulting in bodily injury or equipment damage. Each burner should be supervised by a combustion safeguard and only qualified personnel should install, make system adjustments and perform any required service.



ORDAN THERMAL PRODUCTS LTD
 Combustion Equipment & Controls for Industry
 21 Amber St # 9, Markham Ontario Canada L3R 4Z3
 Tel: (905) 475-9292 Fax: (905) 475-3286
 www.ordanthermal.com

NOTICE: PYRONICS practices a policy of continuous improvement in the design of its products. It reserves the right to change the specifications at any time without prior notice.

res sou	Zero pressure compensation enabling	0	R/W	206	0	Off
					1	butt
					2	ext
					3	All
					4	ser
Ptresh	Minimum pressure for enabling of reading	2	R/W	100	0 ÷ 500	
tshow	Displaying time of quantity different from default	0	R/W	218	1 ÷ 255	
brigtns	Adjustment of display luminosity	0	R/W	205	1 ÷ 7	
Pres.Oc	Differential pressure of reference at 0 °C	1	R	07	0 ÷ 9999	
Prs.Oinc	Differential pressure of reference at 0 °C referred to Flow Inc	1	R	08	0 ÷ 9999	
T CmPSou	Source of compensation temperature	0	R/W	224	0	Off
					1	Ser.D
					2	TC1
Temp.Def	Input temperature of default fluid	0	R/W	154	0 ÷ 1300	
P CmPSou	Source of compensation pressure	0	R/W	225	0	Off
					1	Ser.D
					2	Ain1
Pres.Def	Input pressure of default fluid	1	R/W	155	0 ÷ 9999	
U.PrsVis	Measuring unit selected for pressure displaying	0	R/W	235	0	mbar
					1	mmH2O
					2	Pa
					3	Inc H2O
U.FlWVis	Measuring unit selected for flow displaying	0	R/W	237	0	Nm3/h
					1	cfm
U.TmpVis	Measuring unit selected for temperature displaying	0	R/W	238	0	°C
					1	°F

CAUTION: Operation of combustion equipment can be hazardous resulting in bodily injury or equipment damage. Each burner should be supervised by a combustion safeguard and only qualified personnel should install, make system adjustments and perform any required service.



ORDAN THERMAL PRODUCTS LTD
 Combustion Equipment & Controls for Industry
 21 Amber St # 9, Markham Ontario Canada L3R 4Z3
 Tel: (905) 475-9292 Fax: (905) 475-3286
www.ordanthermal.com

NOTICE: PYRONICS practices a policy of continuous improvement in the design of its products. It reserves the right to change the specifications at any time without prior notice.

PROGRAMMING MODE - HARDWARE MENU

PARAMETER	DESCRIPTION	DEC. POINTS	READ/WRITE	DEC. ADDRESS	VALUES	
HWR EXP	Expansion card	0	R/W	209	0	no
					1	EX.P.C
					2	Drim
TC1 type	TC1 input thermocouple type	0	R/W	210	0	J
					1	K
TC1 ofst	Offset reading of TC1 thermocouple	0	R/W	121	-50 ÷ 50	
Out1mALo	output Out1 lower threshold calibration	0	R/W	124	0 ÷ 9999	
Out1mAHi	output Out1 upper threshold calibration	0	R/W	123	0 ÷ 9999	
Ai1 type (*)	Ain1 input signal type	0	R/W	212	0	0.0
					1	4.0
AI1valLo (*)	Numeric value corresponding to Ain1 input lower threshold	1	R/W	151	-9999 ÷ 9999	
AI1valHI (*)	Numeric value corresponding to Ain1 input upper threshold	1	R/W	152	-9999 ÷ 9999	
Func DI1	Din1 digital input function	0	R/W	213	0	ZE.Pr
					1	Tot.r
					2	Ou.Fr
Pres.In	Reading type (either positive or negative)	0	R/W	233	0	pos
					1	neg
U.Prs.Prg	Measuring unit used while programming	0	R/W	234	0	mbar
					1	mmH2O
Delta Fp	Value of the pressure delta necessary to disable filtering	0	R/W	174	0 ÷ 4000	

(*): Parameters available only with expansion card and if C.EXP is selected in parameter "HWR EXP"

CONTROLS AND PARAMETERS FROM SERIAL

PARAMETER	DESCRIPTION	DEC. POINTS	READ/WRITE	DEC. ADDRESS	VALORI	
Ser.Tem	Temperature compensation from serial line	0	R/W	18	0 ÷ 1300	
Ser.Prs	Pressure compensation from serial line	1	R/W	19	0 ÷ 9999	
Tot.res	Total flow rate resetting from serial line	0	R/W	300	0	disabled
					1	enabled
Pres.res	Zero pressure correction from serial line	0	R/W	301	0	disabled
					1	enabled

CAUTION: Operation of combustion equipment can be hazardous resulting in bodily injury or equipment damage. Each burner should be supervised by a combustion safeguard and only qualified personnel should install, make system adjustments and perform any required service.



ORDAN THERMAL PRODUCTS LTD
 Combustion Equipment & Controls for Industry
 21 Amber St # 9, Markham Ontario Canada L3R 4Z3
 Tel: (905) 475-9292 Fax: (905) 475-3286
www.ordanthermal.com

NOTICE: PYRONICS practices a policy of continuous improvement in the design of its products. It reserves the right to change the specifications at any time without prior notice.

COMMUNICATION ERROR RESPONSE

When ESA PT-II receives a request whose error check is wrong, it sends no answer to its master. If there are mistakes in the request of the master, the device does not answer as requested, but sends an error message where the "function code" is repeated but increased by 128 (80 h) followed by the error code:

ADDRESS	FUNCTION CODE + 128 (80h)	ERROR CODE	ERROR CHECK (CRC) high byte	ERROR CHECK (CRC) low byte
1 byte	1 byte	1 byte	1 byte	1 byte

The possible error codes are described in the table below.

ERROR TYPE	ERROR CODE
Unknown function code or request	05
Reception of timeout	06
Excessive number of Words to either write or read	07

INSTALLATION

- Place ESA PT-II in places where thermal excursions are within the permitted limits, avoid accommodating it close to intense electrical and/or magnetic fields, in places exposed to vibration or in conditions where it might be exposed to irradiated heat, or come in contact with fuels, liquids, solvents, or corrosive gases.
- The equipment must be installed by skilled staff, in compliance with the regulations in force at the time and in the place of installation.
- A minimum protection class of IP40 must be always guaranteed when installing the device on the casing.
- The device must be mounted vertically. The special mounting holes and the holes for cables are on the back cover. In order to make the holes we recommend that you should use either a milling cutter or tools suitable for thermoplastic material, having the correct diameter for the cable gland to be mounted. Threaded holes should be used in order to avoid modifying the protection degree.
- The instrument must be electrically connected in a permanent way. Check that connections, supply voltage, frequency and capacity are correct and that the protection ground is connected to the correct terminal by means of adequate terminals.
- Study all technical information and respect it, in particular the phase-neutral polarity, when making electric connections. The type of conductors and their location must be suitable for their application.
- The connections for the transmission of the mA signal from ESA PT-II to the remote supervisor must be executed by means of a screened double-wire cable, (2x1mm²) taking care that screening is grounded from one end only.
- The connection for the compensation thermocouple is to be made by means of compensated cable of the same type as the thermocouple which is being used.
- The connection of the RS-485 serial line must be executed via twisted, shielded cable connected in parallel among all the network users. It is necessary to install end terminations resistances at the beginning and end of the network (on the further nodes). ESA PT-II supplies such resistances, which will have to be discarded when the instrument is not field terminal to the network.
- The pneumatic connections for the pressure input signals (+ / -) can be carried out with copper pipes (6 x 4 mm), avoiding long and U shaped courses. It is advisable to install the device in a high position far from pressure intakes (calibrated flange, anubar, etc.), otherwise steam traps must be duly installed.
- If the instrument is used to measure relative pressure, the signal must be connected to the positive input, on the other hand the negative input must stay open (atmospheric pressure).

CAUTION: Operation of combustion equipment can be hazardous resulting in bodily injury or equipment damage. Each burner should be supervised by a combustion safeguard and only qualified personnel should install, make system adjustments and perform any required service.



ORDAN THERMAL PRODUCTS LTD
 Combustion Equipment & Controls for Industry
 21 Amber St # 9, Markham Ontario Canada L3R 4Z3
 Tel: (905) 475-9292 Fax: (905) 475-3286
 www.ordanthermal.com

NOTICE: PYRONICS practices a policy of continuous improvement in the design of its products. It reserves the right to change the specifications at any time without prior notice.

PNEUMATIC CONNECTIONS

Differential pressure measurement

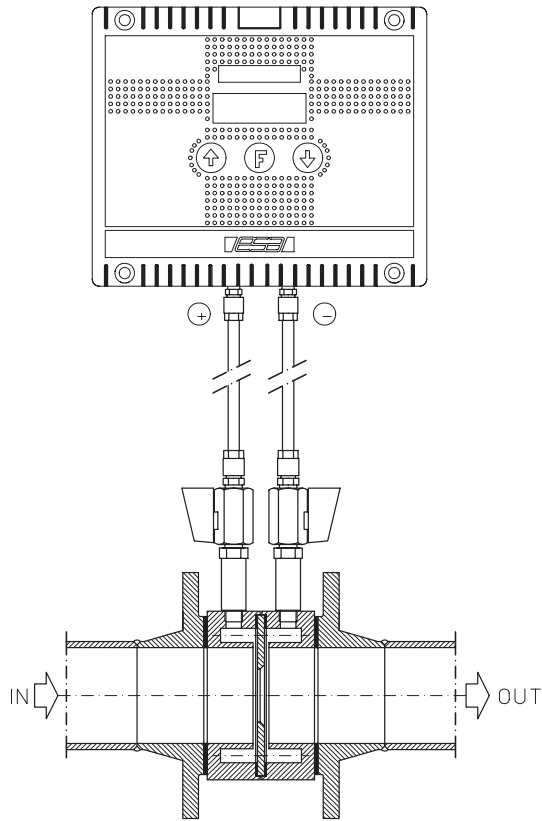

Relative pressure measurement

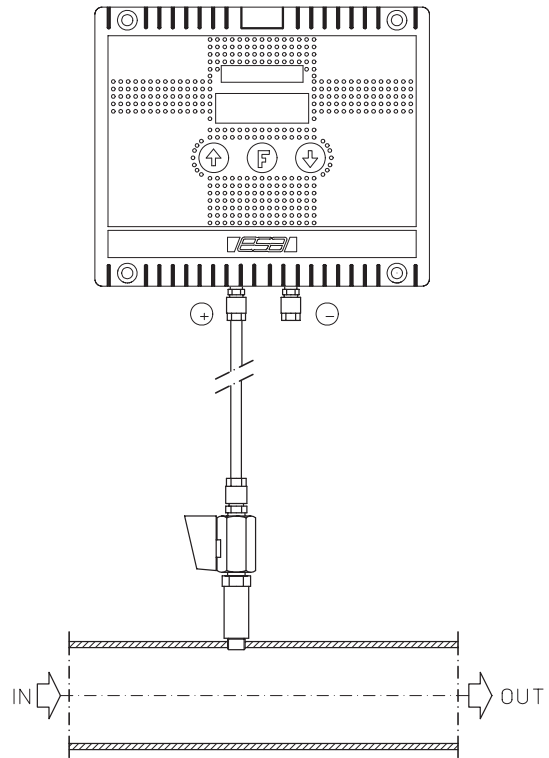

D7210E08

CAUTION: Operation of combustion equipment can be hazardous resulting in bodily injury or equipment damage. Each burner should be supervised by a combustion safeguard and only qualified personnel should install, make system adjustments and perform any required service.



ORDAN THERMAL PRODUCTS LTD
 Combustion Equipment & Controls for Industry
 21 Amber St # 9, Markham Ontario Canada L3R 4Z3
 Tel: (905) 475-9292 Fax: (905) 475-3286
www.ordanthermal.com

NOTICE: PYRONICS practices a policy of continuous improvement in the design of its products. It reserves the right to change the specifications at any time without prior notice.

ELECTRICAL CONNECTIONS

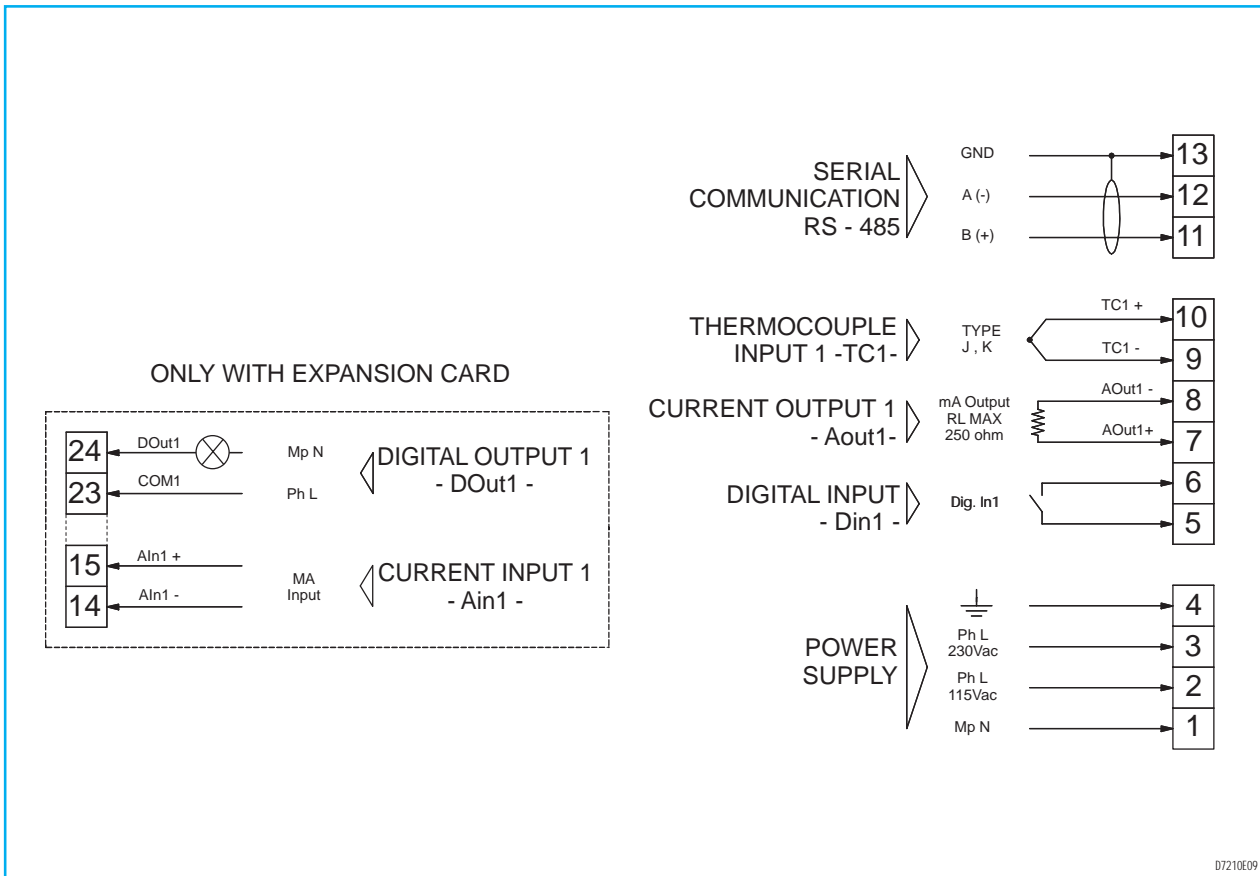

STANDARD TERMINAL BOARD

Pos.	Description	Pos.	Description
1	Power supply neutral	8	Current Out1 output negative
2	Power supply phase 115 Vac	9	TC1 thermocouple input negative
3	Power supply phase 230 Vac	10	TC1 thermocouple input positive
4	Protection ground	11	Communication input positive
5	Digital input 1	12	Communication input negative
6	Digital input 1	13	Communication line screen
7	Current Out1 output positive		

TERMINAL BOARD - EXPC EXPANSION

Position	Description
14	Ain1 current input negative
15	Ain1 current input positive
23	Dout1 digital output
24	Dout1 digital output

CAUTION: Operation of combustion equipment can be hazardous resulting in bodily injury or equipment damage. Each burner should be supervised by a combustion safeguard and only qualified personnel should install, make system adjustments and perform any required service.



ORDAN THERMAL PRODUCTS LTD
 Combustion Equipment & Controls for Industry
 21 Amber St # 9, Markham Ontario Canada L3R 4Z3
 Tel: (905) 475-9292 Fax: (905) 475-3286
www.ordanthermal.com

NOTICE: PYRONICS practices a policy of continuous improvement in the design of its products. It reserves the right to change the specifications at any time without prior notice.

OUTLINE DIMENSIONS

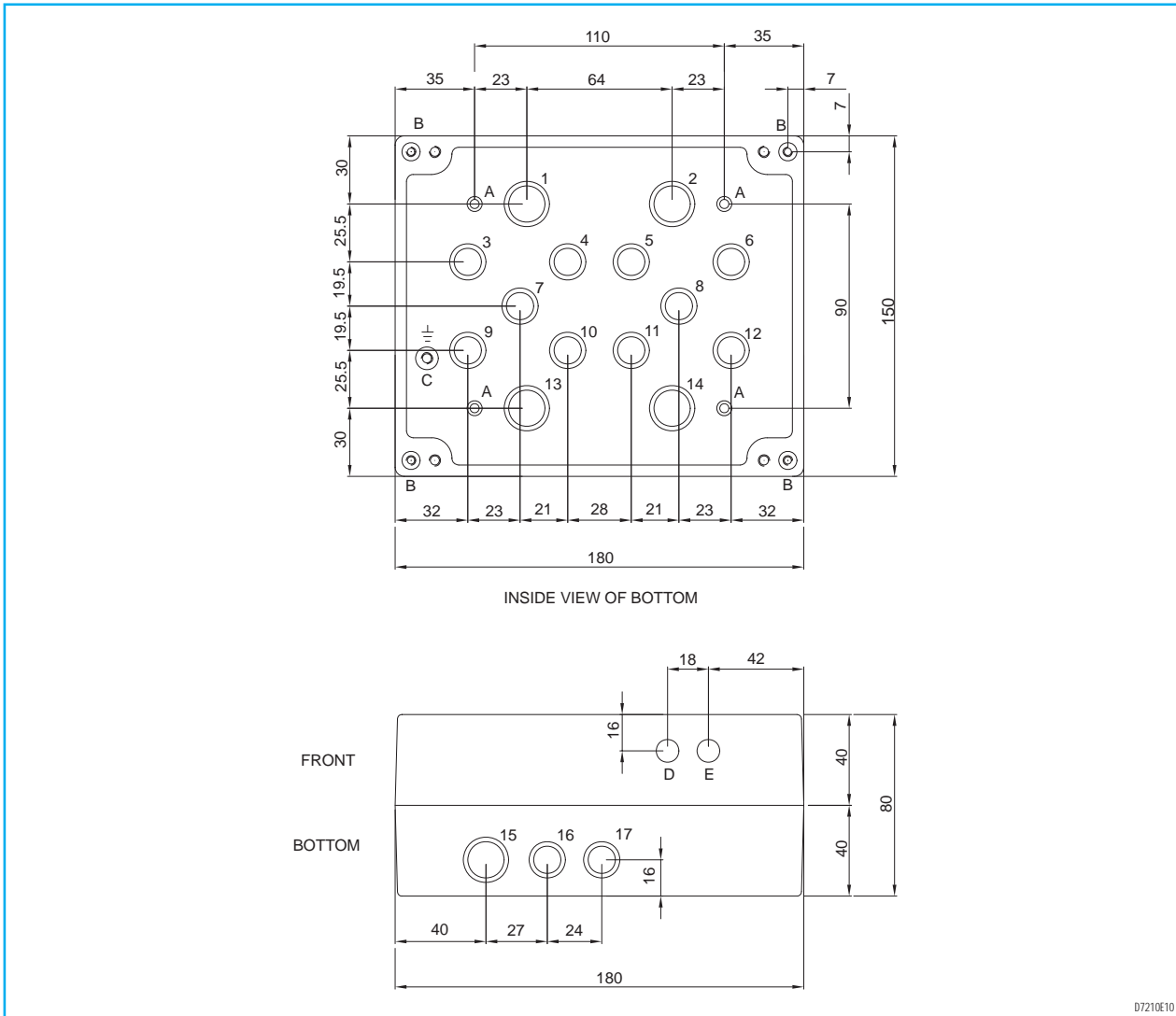

HOLES FOR CABLE ENTRY	DIAMETER mm	CABLE GLAND
3 - 4 - 5 - 6 - 7 - 8 9 - 10 - 11 - 12 - 16 - 17	16.0	M16X1 - PG9
1 - 2 - 13 - 14 - 15	20.0	M20X1 - PG11

POS.	OTHER ELEMENTS
A	Pre-cut fixing holes (old panels)
B	Fixing holes with M4 thread
C	Screw for grounding
D	Pressure positive input
E	Pressure negative input

CAUTION: Operation of combustion equipment can be hazardous resulting in bodily injury or equipment damage. Each burner should be supervised by a combustion safeguard and only qualified personnel should install, make system adjustments and perform any required service.



ORDAN THERMAL PRODUCTS LTD
 Combustion Equipment & Controls for Industry
 21 Amber St # 9, Markham Ontario Canada L3R 4Z3
 Tel: (905) 475-9292 Fax: (905) 475-3286
www.ordanthermal.com

NOTICE: PYRONICS practices a policy of continuous improvement in the design of its products. It reserves the right to change the specifications at any time without prior notice.

ORDER CODE

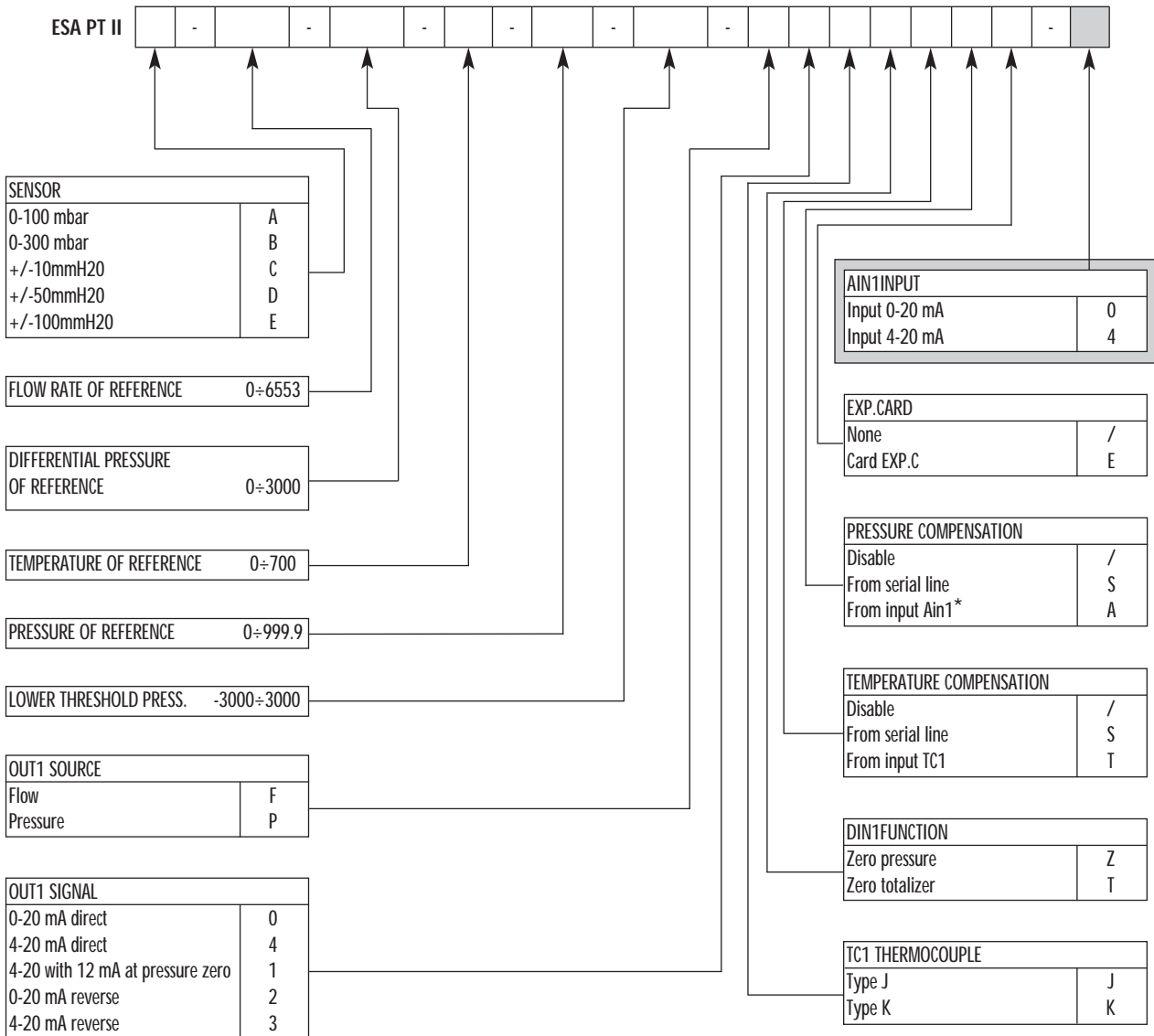

(*) Configuration which is available only with EXP-C expansion card

■ To be used only with EXP-C expansion card.

CAUTION: Operation of combustion equipment can be hazardous resulting in bodily injury or equipment damage. Each burner should be supervised by a combustion safeguard and only qualified personnel should install, make system adjustments and perform any required service.



ORDAN THERMAL PRODUCTS LTD
 Combustion Equipment & Controls for Industry
 21 Amber St # 9, Markham Ontario Canada L3R 4Z3
 Tel: (905) 475-9292 Fax: (905) 475-3286
 www.ordanthermal.com

NOTICE: PYRONICS practices a policy of continuous improvement in the design of its products. It reserves the right to change the specifications at any time without prior notice.