

# REPAIR KIT IRC-1 BURNERS

MODEL: 3212-IRC-1-RK

REVISION 0

BULLETIN  
3212

## FIELD REPAIR INSTRUCTIONS

1. Remove burner assembly from installation by removing Socket Head Capscrew (Item No. 7), from Distributor (Item No. 1), as shown in Figure 1 below.
2. Discard the existing Retaining Rails (Item No. 3), Ceramic Grid Section (Item No. 4), Ceramic Orifice Plates (Item No. 5), Gasket (Item No. 6)
3. Clean inside surface of Burner Body (Item No. 2). See Figure 1 below.
4. Burner is now ready to be reassembled.
5. Install new Gasket (Item No. 6), in Burner Body (Item No. 2).
6. Install Socket Head Capscrew (Item No. 7), in Burner Body (Item No. 2).
7. Lay two Ceramic Orifice Plates (Item No. 5) on a flat surface, making sure that they are completely together at the center hole as shown in Figure 1. Assemble two Ceramic Grid Sections (Item No. 4) on top of the Orifice Plates, making sure of proper alignment of Gas Ports to center line of ribs in Top Grid. Assemble Stainless Steel Retaining Rails (Item No. 3) into side slots of Top Grids and press complete assembly into Cast Iron Burner Body, making sure that the complete assembly is centered in the length of the casting. Make sure that the Orifice Plates are completely together in the center before proceeding with the next step.
8. Press down firmly on Ceramic Grid Section and insert small rod or Phillips Head Screwdriver through holes in Burner Body (Item No. 2), into holes of Retaining Rails (Item No. 3), and pull lance outward to lock Ceramic Assembly to Burner Body as shown. When assembly is complete, all Ceramic sections must be tight in Burner Body to prevent leakage at gasket seal.
9. Install Burner Assembly on Distributor (Item No. 1), and secure in place with Socket Head Capscrew (Item No. 7).
10. Burner is now ready for service.

FIGURE 1

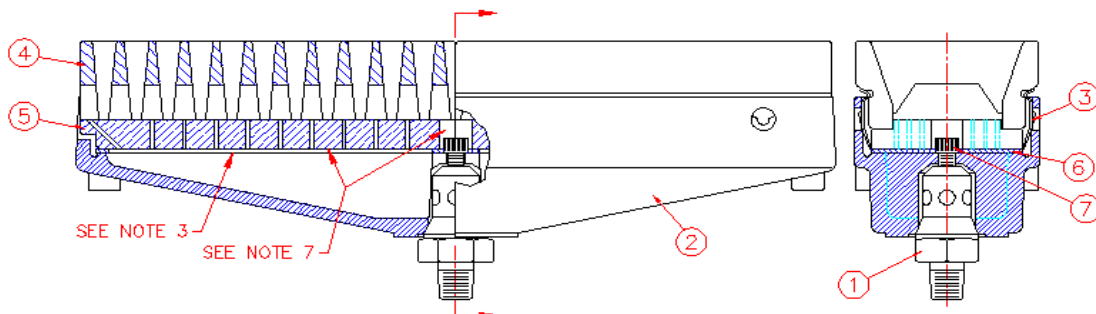

**CAUTION:** Operation of combustion equipment can be hazardous resulting in bodily injury or equipment damage. Each burner should be supervised by a combustion safeguard and only qualified personnel should install, make system adjustments and perform any required service.



**ORDAN THERMAL PRODUCTS LTD**  
Combustion Equipment & Controls for Industry  
21 Amber St # 9, Markham Ontario Canada L3R 4Z3  
Tel: (905) 475-9292 Fax: (905) 475-3286  
[www.ordanthermal.com](http://www.ordanthermal.com)

**NOTICE:** Pyronics practices a policy of continuous improvement in the design of its products. It reserves the right to change the specifications at any time without prior notice.

# REPAIR KIT IRC-1 BURNER

BULLETIN  
3212  
PAGE NO.2

## EXPLODED VIEW

