

# XDF BURNERS

## DUAL FUEL EXCESS AIR BURNER

MODEL: 3610, 3651

Revision: 0

BULLETIN  
3610, 3651

### FEATURES

- Burns all fuel gases or light oils
- Nozzle mix design for on ratio control or excess air
- 350% excess air all sizes on gas or oil
- Turndown 10:1 on ratio with single air valve control
- Excellent flame stability instant lighting with either fuel
- Sealed construction for back pressure firing to 10 PSIG
- Pilot, flame rod and U.V. scanner mountings in tapped holes
- Unique stepped tunnel design
- Patented atomization
- Simplified construction - no moving parts



### DESCRIPTION

Cool Flame series XDF dual fuel excess air burners are nozzle mixing oil or gas units designed for up to 350% excess air or on ratio firing. A unique stepped tunnel design produces excellent flame stability at all firing rates.

All sizes are designed for turndown of ten to one on ratio with 16 oz. combustion air pressure. Pressure balancing of gas zero governor and oil-air ratio regulators provides constant fuel to air mixes for on ratio firing over the turndown range. The burner is designed for sealed firing in positive, neutral or negative pressure combustion chambers.

### EXCESS AIR OPERATION

High speed heat transfer will occur in convection systems with maximum turbulence and scrubbing action of the hot gases against the work pieces. High discharge velocities from burners increases furnace hot gas circulation and promotes rapid heat transfer.

Excess air systems use a constant air flow and "on-ratio" combustion at high fire. Only the fuel flow is varied for heat input turndown. The total volume of hot gases and velocity remains nearly constant at all firing rates. Furnace pressures, turbulence and heat transfer rates are uniform.

Shorter firing cycles and lower fuel consumption result from better temperature uniformity requiring less soak time.

Excess Air Burners are variable temperature air heaters. At high fire flame temperatures may be 2500°F or higher. As fuel only is decreased, exit gas temperatures drop to as low as 1200°F with 350% excess air.

"On ratio" firing systems can produce the required velocities on high fire but drop to 10% to 15% of this velocity on low fire.

**CAUTION:** Operation of combustion equipment can be hazardous resulting in bodily injury or equipment damage. Each burner should be supervised by a combustion safeguard and only qualified personnel should install, make system adjustments and perform any required service.



**ORDAN THERMAL PRODUCTS LTD**  
Combustion Equipment & Controls for Industry  
21 Amber St # 9, Markham Ontario Canada L3R 4Z3  
Tel: (905) 475-9292 Fax: (905) 475-3286  
[www.ordanthermal.com](http://www.ordanthermal.com)

**NOTICE:** Pyronics practices a policy of continuous improvement in the design of its products. It reserves the right to change the specifications at any time without prior notice.

# XDF BURNERS

## CAPACITY TABLE - ON RATIO FIRING

Catalog Number	Air Pipe Sizes	16 OSI AIR				24 OSI AIR			
		Atomizing Air Flow CFH*	Oil Flow GPH	Combustion Air Flow CFH	Gas Input 1000's BTU/hr.	Atomizing Air Flow CFH	Oil Flow GPH	Combustion Air Flow CFH	Gas Input 1000's BTU/hr.
16XDF	2"	700	5	6300	630	850	6	7800	780
24XDF	3"	1400	10	12600	1260	1700	12	15600	1560
32XDF	4"	2800	20	25200	2520	3400	24	31000	3100
48XDF	6"	5600	40	50400	5000	6800	49	62000	6200

NOTE: Gas pressure required at inlet to Balanced Zero Governor 4" W. C. minimum with oil lances retracted to stops. With gas pressure 2 osi higher than air pressure oil lances need not be retracted. Gas pressure must be higher than air pressure for all positive pressure combustion chamber firing.

Oil pressure required at inlet to Oil-Air Ratio Regulator 40 to 50 psig.

\*Minimum recommended atomizing air pressure is 20 osi.

## CAPACITY TABLE - EXCESS AIR FIRING

Catalog Number	Air Pipe Size	Gas Operation			Oil Operation			
		Air Flow SCFH	1000's BTU/hr. Gas		Atomizing Air SCFH	Combustion Air SCFH	Oil Flow GPH	
			Max.	Min.			Max.	Min.
16XDF	2"	6300	630	30	700	6300	5	0.5
24XDF	3"	12600	1260	60	1400	12600	10	1
32XDF	4"	25200	2520	120	2800	25200	20	2
48XDF	6"	50400	5040	250	5600	50400	40	4

Capacities are for 16 osi air pressure, 3 osi gas pressure and 20 psig oil pressure delivered to the burner at maximum firing rates. Air flows remain constant at all firing rates. Only fuel flow is varied.

## GAS OPERATION - ON RATIO

Gas flow delivered thru the control valves at 4" W. C. or higher is controlled by the Balanced Zero Governor. The combustion air impulse to the Governor regulates the outlet gas pressure in direct proportion to the air pressure. The gas adjuster sets the gas to air ratio for proper combustion. Once set at high fire the gas adjuster is locked in a fixed position.

When firing gas fuels with pressure less than combustion air pressure, the oil lance and nozzle must be retracted.

With the oil lance and nozzle retracted, the stop on the oil lance positions the nozzle to increase gas turbulence, air mixing and shorten flame lengths.

Modulating the combustion air valve reduces the air flow thru the burner and the impulse pressure to the governor. This produces an outlet gas pressure proportional to the air pressure for constant combustion efficiency. See Catalog Section 5 for a complete description of the Balanced Zero Governors (5101).

# XDF BURNERS

## TYPICAL OIL SYSTEM - ON RATIO

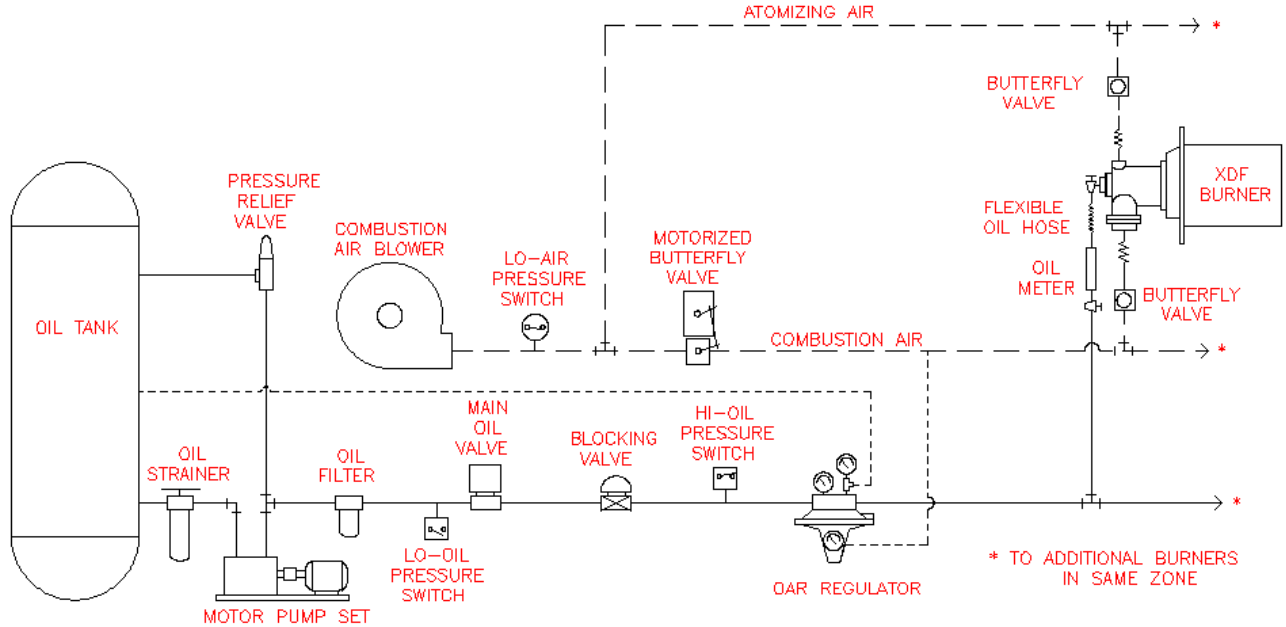

## TYPICAL DUAL FUEL SYSTEM - ON RATIO

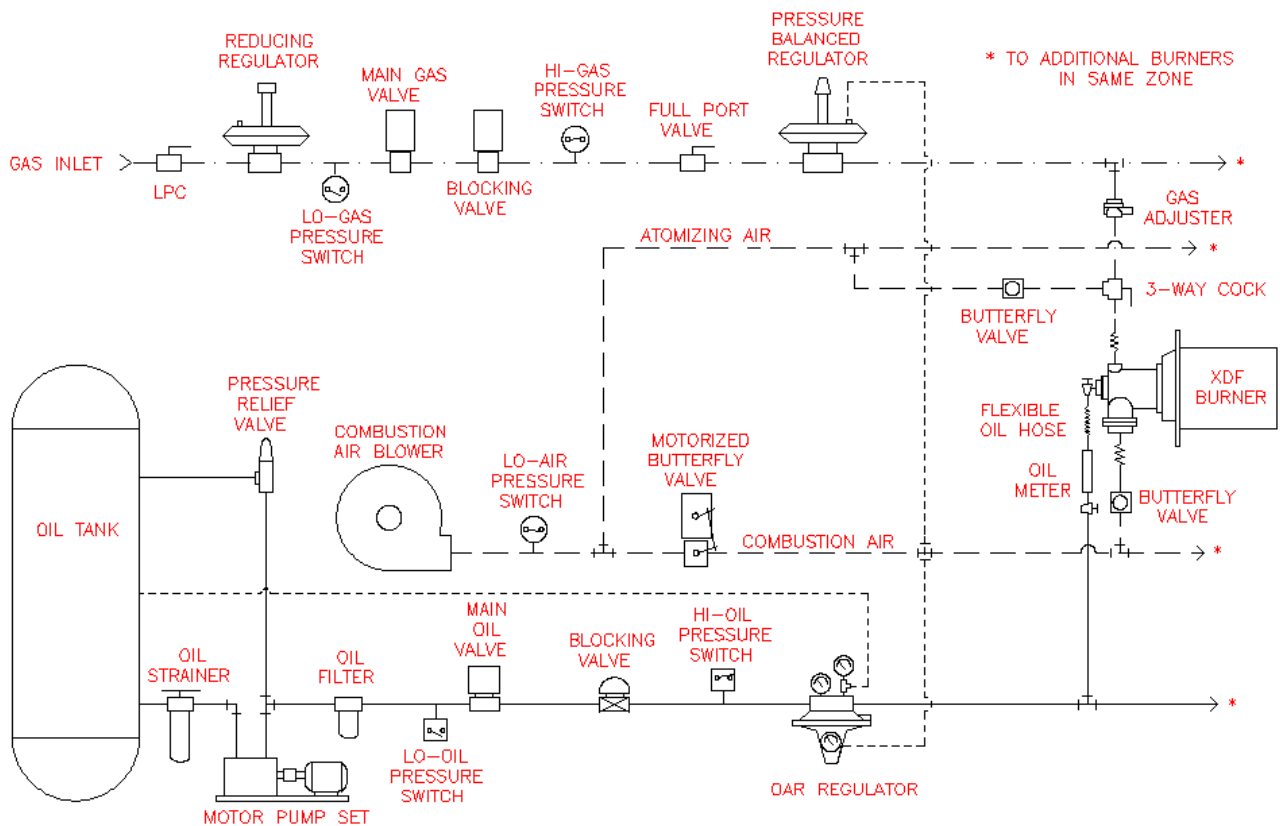

**CAUTION:** Operation of combustion equipment can be hazardous resulting in bodily injury or equipment damage. Each burner should be supervised by a combustion safeguard and only qualified personnel should install, make system adjustments and perform any required service.



**ORDAN THERMAL PRODUCTS LTD**  
Combustion Equipment & Controls for Industry  
21 Amber St # 9, Markham Ontario Canada L3R 4Z3  
Tel: (905) 475-9292 Fax: (905) 475-3286  
[www.ordanthermal.com](http://www.ordanthermal.com)

**NOTICE:** Pyronics practices a policy of continuous improvement in the design of its products. It reserves the right to change the specifications at any time without prior notice.

# XDF BURNERS

## OIL OPERATION - ON RATIO

Oil is delivered by the pumping system thru shutoff valves to the inlet of the Oil-Air Ratio Regulator at 40 to 50 PSIG. With combustion air full on the 16 oz. air impulse pressure sets the Oil-Air Ratio Regulator at 32 PSIG outlet pressure. Oil limit orifice valve sets the oil to air ratio for proper combustion on hi-fire.

Oil flows tangentially thru the patented nebulizer nozzle spinning into the atomizing chamber. Atomizing air at 20 psi minimum, enters this chamber tangentially converting the oil stream into an extremely fine mist. Combustion begins in the

expansion section of the refractory block and is rapidly completed with the highly turbulent main combustion air.

Modulating the combustion air valve reduces air flow thru the burner and the impulse pressure to the Oil-Air Ratio Regulator reducing the oil pressure delivered to the burner. Accurate proportioning of both oil and air over a capacity turndown range up to 10 to 1 results. At low fire the main air is complete shut off with the atomizing air flow supplying combustion requirements. Lo-fire fuel flow is set with the lo-fire adjustment on the oil-air ratio regulator.

## EXCESS AIR OPERATION

Maximum burner temperatures are obtained at high fire with proper air to fuel ratio. As fuel flow only is reduced with air constant, burner output temperature lowers.

With constant air flow, total volume of combustion products and discharge velocities will remain nearly constant. This produces an extremely wide effective turndown ratios. Transmission of heat throughout a work load remains uniform.

A continuous pilot for each burner is recommended.

Typical recommended piping arrangements for a constant air flow system is shown. Each burner is individually adjusted

for "on-ratio" combustion at maximum air flow.

Turndown is obtained from the master gas and/or oil flow control valve for the system or zone. Air butterfly valves at each burner are used to balance the heat patterns on multiple burner systems.

Orifice flow meters (5270) are suggested to measure gas and air flows.

Electronic flame detection systems are usually required on units that may be operated below 1400°F. For multiple burner flame protection see Sens-A-Flame data sheet 7112.

## EXCESS AIR - TYPICAL PIPING OIL SYSTEM

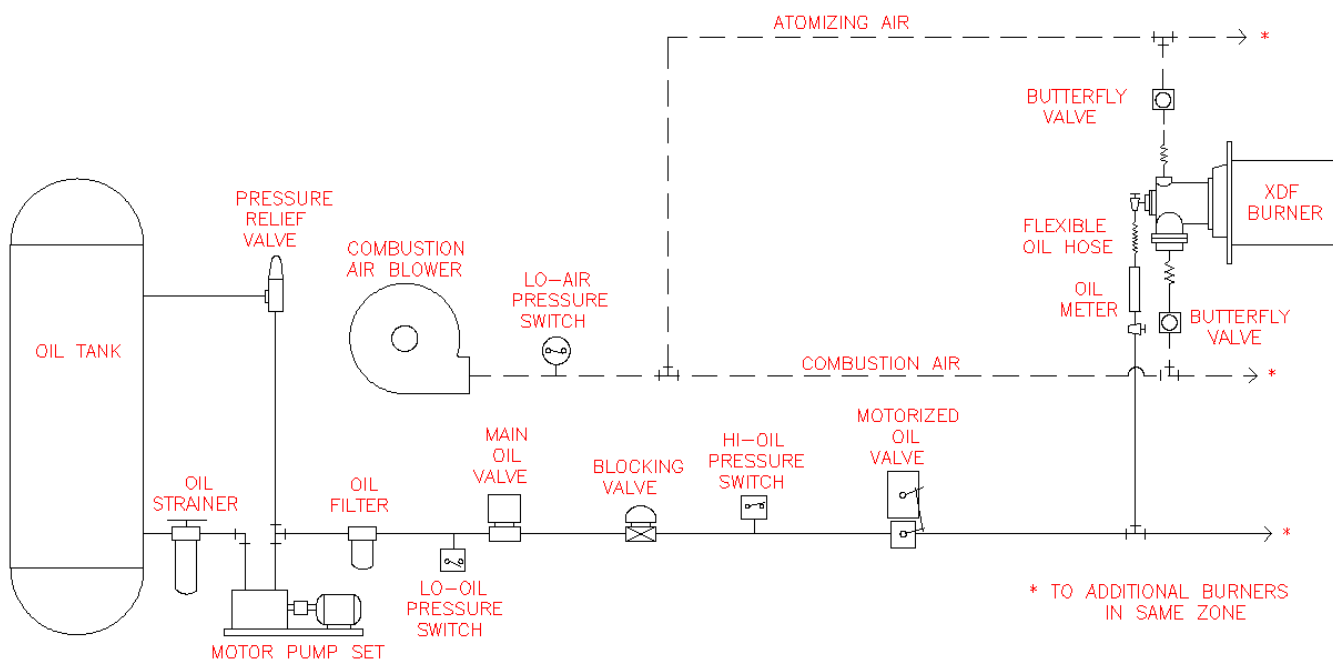

# XDF BURNERS

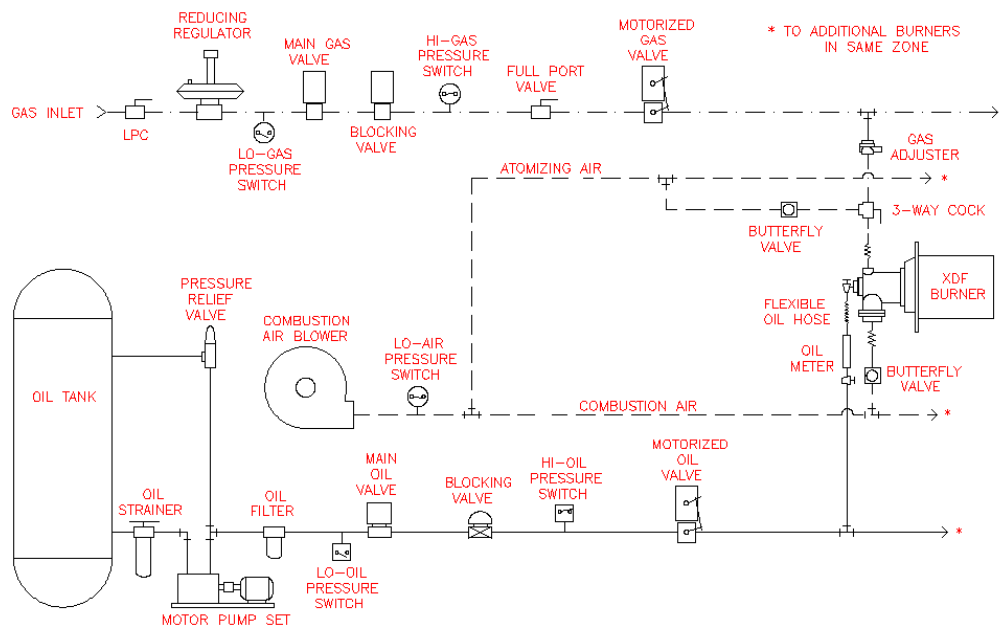

## EXCESS AIR - TYPICAL PIPING DUAL FUEL

1. Close all fuel valves including gas adjuster.
2. Position 3-way 2 port valve in gas position (if Dual Fuel System).
3. Open air valves wide (manual and automatic) for purging - start combustion air blower, check rotation. Check impulse pressure to top of BZR gas regulator.
4. Turn control air valve back to low position (1/2" W.C.)
5. Light pilot or hold manual torch to ignition port.
6. Open main gas shut-off valve.
7. Open burner gas shut-off valve, if one is used (Zone valve is multiple burner system).
8. After lighting burner, or burners, slowly open main air valve and gas adjuster to high fire position. Return main air valve to low position, check flame characteristics and stability and all inputs.
9. If automatic control, set main valve linkage for minimum and maximum firing rates

## OIL OPERATION

1. Close all fuel valves, including manual oil adjusting valve.
2. Position 3-way 2 port valve in air position.
3. Start combustion air blower (check rotation) and oil pump. (Check oil pressure 40-50 PSIG). Check impulse pressure to OAR ratio regulator.
4. Open main air valve wide (manual and automatic) for purging. Return to low position (1/2" W.C.).
5. Open safety shut-off valve if one is used.
6. Light pilot or hold manual torch to ignition port. Slowly open oil stop valve. Quickly open oil limit valve until burner ignites. If more than one burner is used ignite all burners on low fire. It is desirable to have individual burner manual air butterfly valves on a multiple burner system.
7. Allow sufficient time for heat up of burner tile.
8. Advance main air valve and oil limit valve to high fire position. Keep burner slightly rich until high fire position is determined. Adjust oil valve at maximum input. Slowly return main air valve to low position. Check combustion characteristics at all rates. If automatic control is utilized, set linkage for desired minimum and maximum rates.
9. Refer to OAR Ratio Regulator Data Sheet for initial instructions.
10. When shutting down burners, turn off oil valve upstream of OAR regulator and allow to purge. Shut off oil stop valve after purge.

**CAUTION:** Operation of combustion equipment can be hazardous resulting in bodily injury or equipment damage. Each burner should be supervised by a combustion safeguard and only qualified personnel should install, make system adjustments and perform any required service.



**ORDAN THERMAL PRODUCTS LTD**  
Combustion Equipment & Controls for Industry  
21 Amber St # 9, Markham Ontario Canada L3R 4Z3  
Tel: (905) 475-9292 Fax: (905) 475-3286  
[www.ordanthermal.com](http://www.ordanthermal.com)

NOTICE: Pyronics practices a policy of continuous improvement in the design of its products. It reserves the right to change the specifications at any time without prior notice.

# XDF BURNERS

BULLETIN 3610, 3651  
PAGE NO. 6

## SERVICE CHECKING POSSIBLE SOURCES OF TROUBLE

### GAS

- a) Low gas pressure
- b) Impulse pressure to gas regulator too low
- c) Clogged filter on blower
- d) Ruptured diaphragm in regulator

### OIL

- a) Dirt-in (1) air line, (2) oil line, (3) oil tank, (4) strainers
- b) Pump - (1) air leak in suction line, (2) pump instability
- c) Air pressure - (1) too low for atomization
- d) Full flow relief valve setting

## DIMENSIONS SINGLE TUNNEL XDF

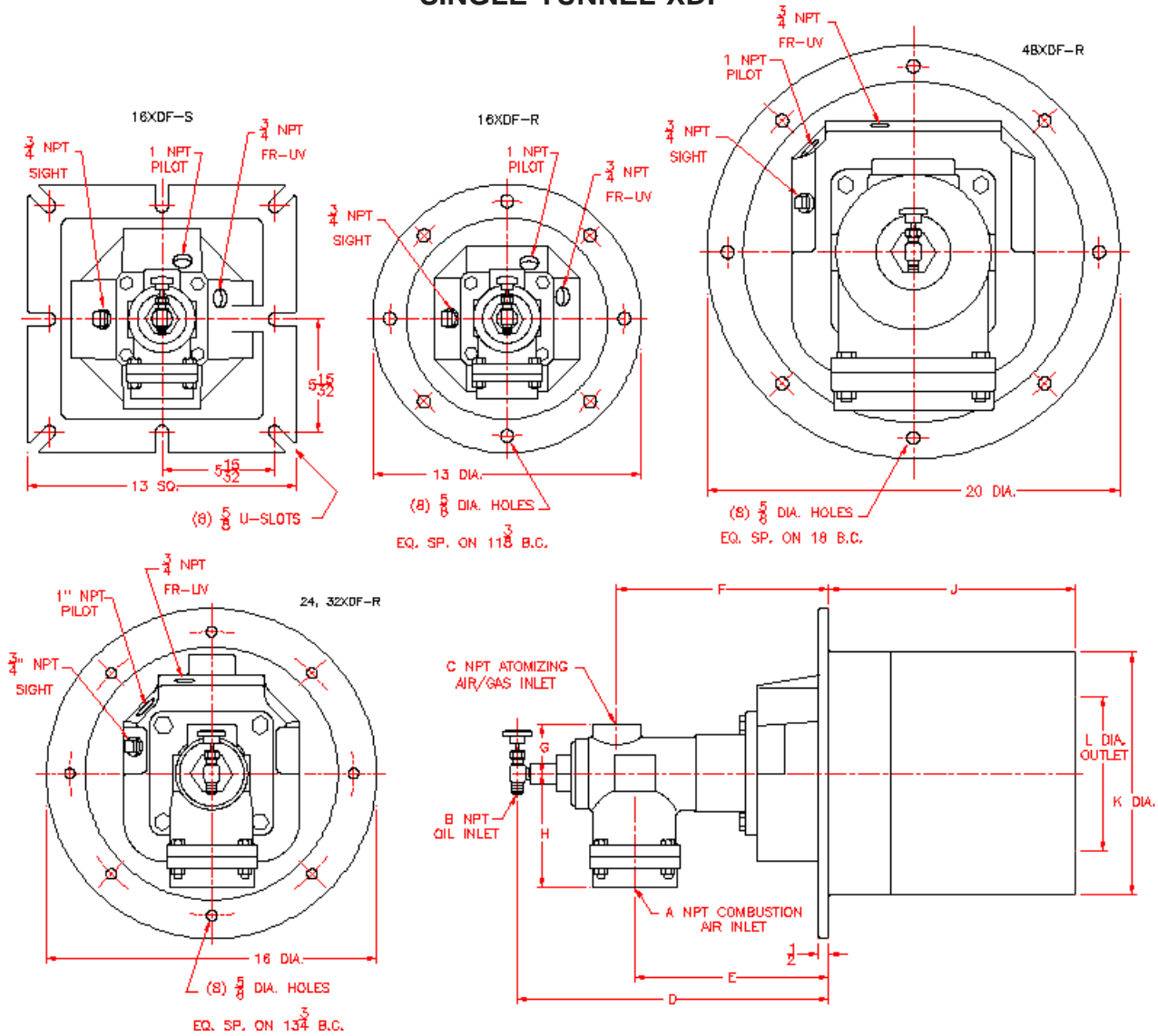

## XDF DIMENSIONS TABLE

Model No.	A NPT	B NPT	C NPT	D	E	F	G	H	J	K DIA	L DIA	WT LBS
16XDF-S	2	1/8	1	12	7-1/8	8	2-3/8	3-7/8	10	9 SQ.	5	100
16XDF-R	2	1/8	1	11-1/8	6-1/4	7-1/8	2-3/8	3-7/8	10	8	5	70
24XDF-R	3	1/4	1-1/2	15-1/8	9-3/8	10-1/4	2-3/8	5-1/2	12	11-3/4 D.	7-1/2	150
32XDF-R	4	1/4	2	15	9-1/4	10-1/8	3-1/8	5-5/8	12	11-3/4	7-1/2	165
48XDF-R	6	1/4	3	17-1/8	10-1/4	11-3/4	4-1/2	7-5/8	13	15-3/4	11	300

# XDF BURNERS

## DIMENSIONS MULTI-TUNNEL XDF

3651 24-4 XDF APPROX. WEIGHT 900 LBS

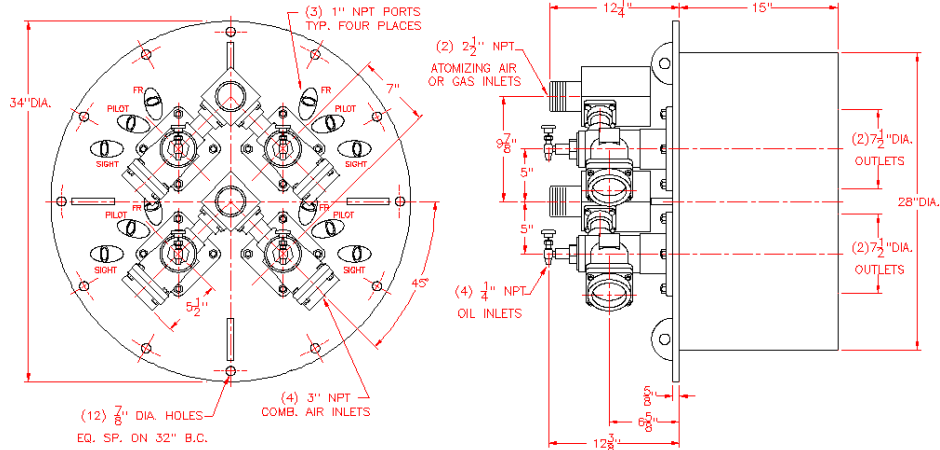

3651 32-4 XDF APPROX. WEIGHT 1200 LBS

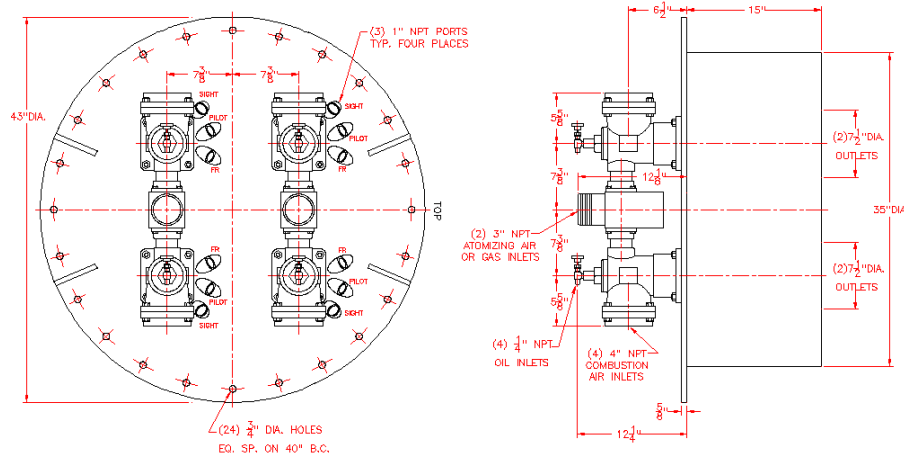

3651 48-2 XDF APPROX. WEIGHT : 1900 LBS

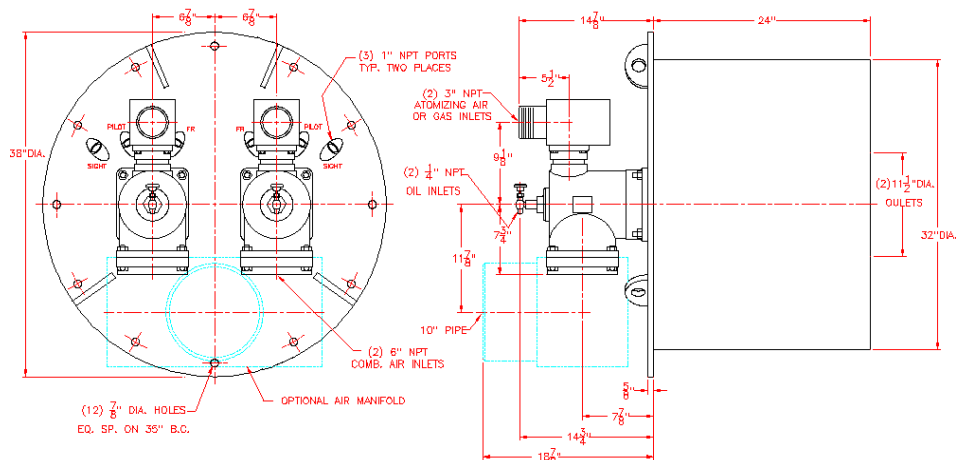

CAUTION: Operation of combustion equipment can be hazardous resulting in bodily injury or equipment damage. Each burner should be supervised by a combustion safeguard and only qualified personnel should install, make system adjustments and perform any required service.



**ORDAN THERMAL PRODUCTS LTD**  
Combustion Equipment & Controls for Industry  
21 Amber St # 9, Markham Ontario Canada L3R 4Z3  
Tel: (905) 475-9292 Fax: (905) 475-3286  
www.ordanthermal.com

NOTICE: Pyronics practices a policy of continuous improvement in the design of its products. It reserves the right to change the specifications at any time without prior notice.

# XDF BURNERS

BULLETIN 3610, 3651  
PAGE NO. 8

3651 48-3 XDF APPROX. WEIGHT 2000 LBS

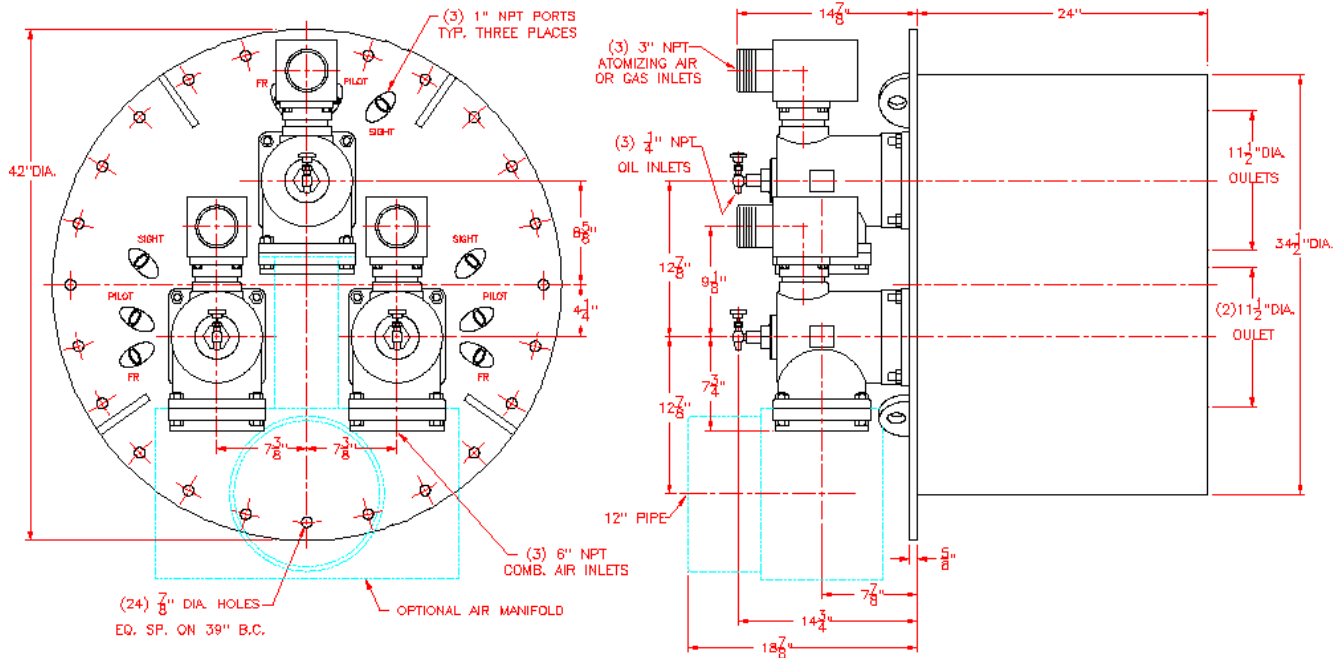

3651 48-4 XDF APPROX. WEIGHT 2200 LBS

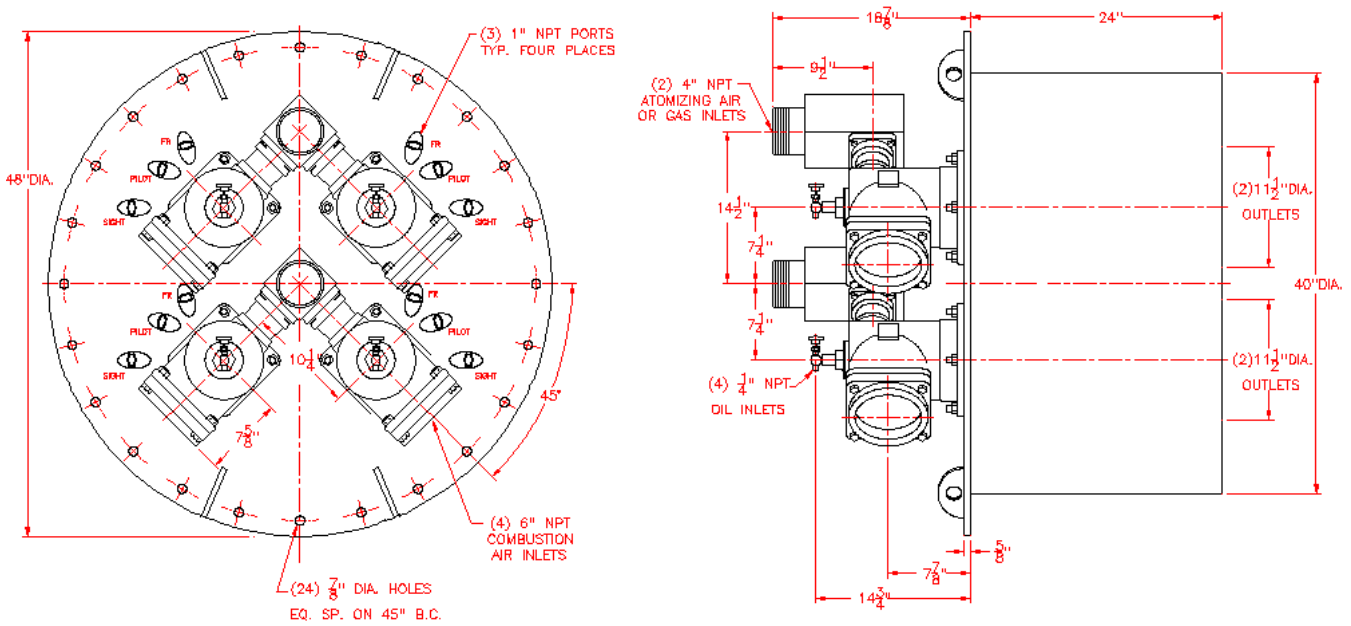

# XDF BURNERS

BULLETIN 3610, 3651  
PAGE NO. 9

3651 48-6 XDF APPROX. WEIGHT 2900 LBS

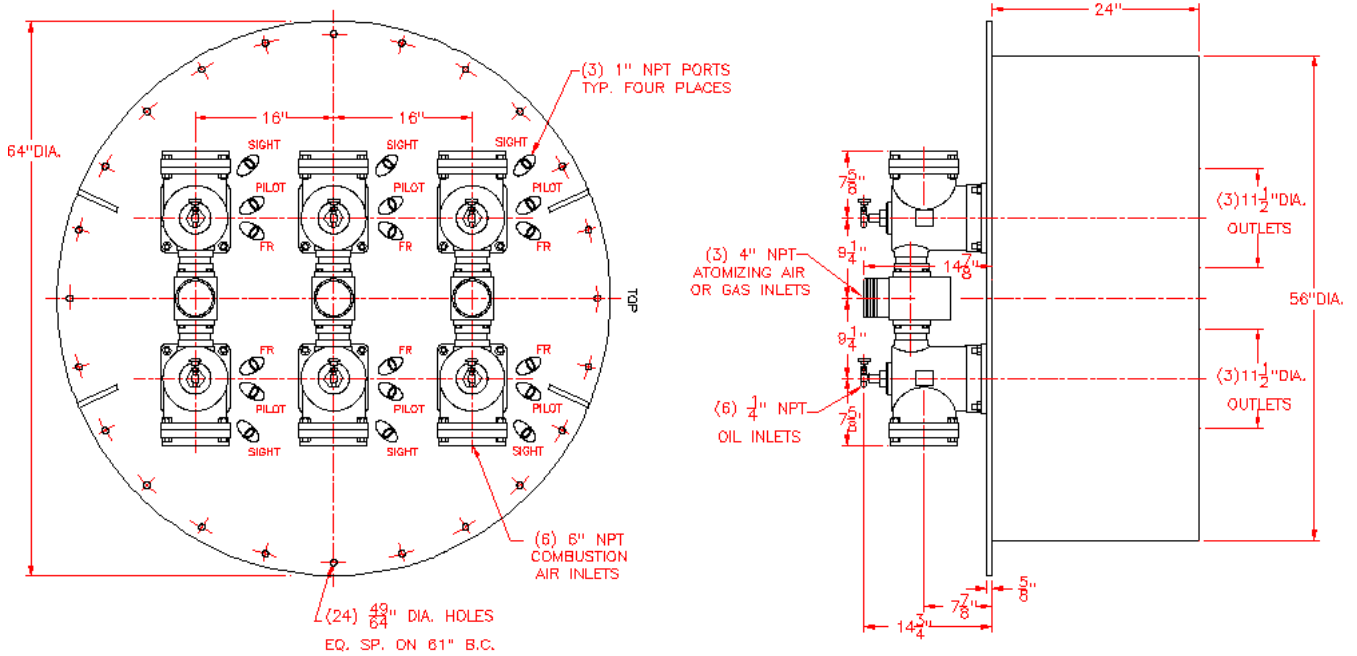

## ORDERING INFORMATION

- |  |   |
|--|---|
| 1. Quantity and catalog number of each burner. Specify block assembly by letter designation. | 4. Select proper OAR regulator, valves, etc.                                      |
| 2. Designate type of oil (and gas if dual-fuel).   | 5. State pressure conditions in combustion chamber (negative, neutral, positive). |
| 3. Specify catalog number of pilot assembly.   | 6. Complete shipping instructions.  |

**CAUTION:** Operation of combustion equipment can be hazardous resulting in bodily injury or equipment damage. Each burner should be supervised by a combustion safeguard and only qualified personnel should install, make system adjustments and perform any required service.



**ORDAN THERMAL PRODUCTS LTD**  
**Combustion Equipment & Controls for Industry**  
 21 Amber St # 9, Markham Ontario Canada L3R 4Z3  
 Tel: (905) 475-9292 Fax: (905) 475-3286  
[www.ordanthermal.com](http://www.ordanthermal.com)

**NOTICE:** Pyronics practices a policy of continuous improvement in the design of its products. It reserves the right to change the specifications at any time without prior notice.