

MULTI-RING BURNER

ATMOSPHERIC - MANIFOLDED TYPE

MODEL: 3250

Revision: 0

BULLETIN
3250



DESCRIPTION

Manifold Ring Burners are specially adapted to heating of kettles, rinse tanks, vertical boilers, cauldrons, ovens, stereotype pots and similar applications. They can be supplied with a pilot (Bulletin 3275 - 22AP) so the main burners can be automatically turned on and off, or they may be manually controlled by operation of the cocks controlling the various rings.

Continuous pilots can be supplied to permit turning the main flame on and off as desired. This is desirable with some types of automatic control.

Ring Burners are made in a number of sizes and capacities to fit various types of applications. The bottom entrance burners are commonly used to convert various types of kettles and pots or ovens to gas firing where rather large combustion chambers exist. The L series burners are made specially for appliances, such as industrial washers, where combustion head room is very limited. Because of secondary air limitations, care should be taken when using Series L burners to have better draft, for complete combustion and disposal of products of combustion, than is usually necessary with the other ring burners.

The two center rings are cast together and operate as a unit, but each of the outer rings are separate and have their own injector and cock. Consider the 204M, the entire burner may be used for heating up and then the two outside rings shut off and the center two rings turned down as required to continuously maintain the desired temperature. The minimum capacity achieved is about 8% of the maximum. When the burners are operated as a single unit, the minimum capacity is about 20% of the maximum shown.

All Ring Burners are supplied with fixed orifices in pipe threaded spuds which can easily be changed in the field if different drilling is desirable. Adjustable orifices are available on all series at extra cost.

When installing ring burners, allow head room for combustion and make provisions for ample secondary air and proper disposal of flue products.

The center opening of the No. 1 ring should not be restricted in any way, but the No. 202M may be used with a center tank drain as large as six inches in diameter without restricting necessary secondary air flow.

CAUTION: Operation of combustion equipment can be hazardous resulting in bodily injury or equipment damage. Each burner should be supervised by a combustion safeguard and only qualified personnel should install, make system adjustments and perform any required service.



ORDAN THERMAL PRODUCTS LTD.

Combustion Equipment & Controls for Industry
21 Amber St # 9, Markham Ontario Canada L3R 4Z3
Tel: (905) 475-9292 Fax: (905) 475-3286
www.ordanthermal.com

NOTICE: Pyronics practices a policy of continuous improvement in the design of its products. It reserves the right to change the specifications at any time without prior notice.

MULTI-RING BURNER (ATMOSPHERIC) MANIFOLDED TYPE

BULLETIN 3250
PAGE NO. 2

CAPACITY** SPECIFICATIONS - BTU PER HOUR

Catalog Number	450 to 600 BTU Gases 3" to 4" W. C. Press.	950 to 1200 BTU Gases 4" to 6" W. C.	2500 to 3200 BTU Gases 9" to 12" W. C. Press.	No. Rings Used*		
				1 & 2	3	4
153M	272,000	166,000	166,000	x	x	
202M	335,000	230,000	203,000		x	x
204M	463,000	281,000	281,000	x	x	x

* Center Rings 1 and 2 are cast together and supplied by one venturi. Rings are numbered from the center out.
 ** Capacities shown are based on standard #30M TD port drilling to permit turning down without flash-back.
 Where permissible, greatly increased capacities may be secured by larger drilling. If special drilling is desired, write giving full information.

DIMENSIONS

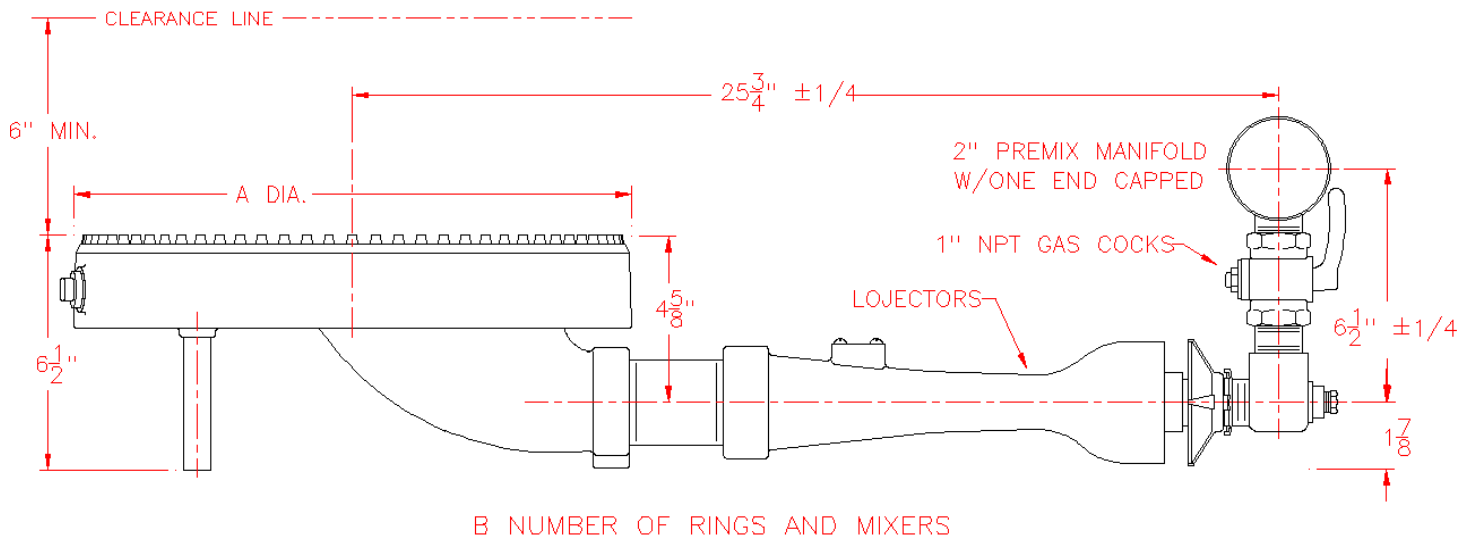

MANIFOLD RING BURNERS

Catalog number	Dimensions - Inches ± 1/8"		Shipping Weight - Lbs.
	A	B	
153M	15 - 1/2	2	75
202M	20 - 1/4	2	100
204M	20 - 1/4	3	130

RING BURNERS (ATMOSPHERIC) SINGLE MIXER TYPE

BULLETIN 3250
PAGE NO. 3

APPROXIMATE CAPACITY* SPECIFICATIONS - BTU PER HOUR

Catalog Number	450 to 600 BTU Gases 3" to 4" W. C. Press.	950 to 1200 BTU Gases 4" to 6" W. C. Press.	2500 to 3200 BTU Gases 9" to 12" W. C. Press.
102C	128,000	78,000	78,000
151C	144,000	88,000	88,000
201C	191,000	115,000	115,000
L-81-C	62,000	37,000	37,000

*Capacities shown are based on standard #30MTD port drilling to permit turning down without flashback. Where permissible, greatly increased capacities may be secured by larger drilling. If special drilling is desired, write giving full information.

DIMENSIONS

Catalog Number	Dimensions - Inches $\pm 1/8"$ unless			Pipe Size D Mixer	E
	A	B	C $\pm 1/4"$		
102C	10 - 1/2	-	23 - 3/4	2	7 - 3/8
151C	15 - 1/2	11 - 3/4	24 - 1/8	2	7 - 3/4
201C	20 - 1/4	16 - 1/2	23	2 - 1/2	5/8

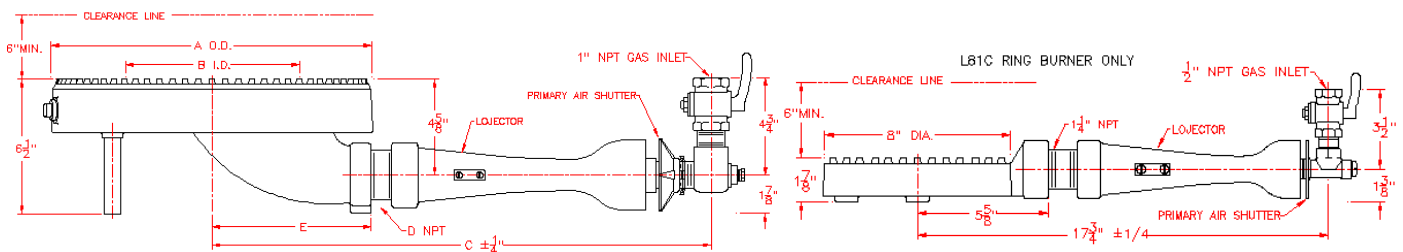

ORDERING INFORMATION

In addition to number required and catalog number, please give the following information:

1. Kind of gas
2. Pressure of gas
3. If special drilling, specify
4. Shipping instructions

If in doubt as to application, we shall be glad to assist in selection of proper burner on receipt of full information as to requirements.

CAUTION: Operation of combustion equipment can be hazardous resulting in bodily injury or equipment damage. Each burner should be supervised by a combustion safeguard and only qualified personnel should install, make system adjustments and perform any required service.



ORDAN THERMAL PRODUCTS LTD.
Combustion Equipment & Controls for Industry
21 Amber St # 9, Markham Ontario Canada L3R 4Z3
Tel: (905) 475-9292 Fax: (905) 475-3286
www.ordanthermal.com

NOTICE: Pyronics practices a policy of continuous improvement in the design of its products. It reserves the right to change the specifications at any time without prior notice.